

**LOW-CURRENT SILICON MMIC
AMPLIFIERS FOR CELLULAR/CORDLESS
TELEPHONES**

**USAGE AND APPLICATIONS OF μ PC8128TB,
 μ PC8151TB, AND μ PC8152TB**

[MEMO]

The information in this document will be updated without notice.

The application circuits and their parameters are for reference only and are not intended for use in actual design-ins.

NESAT is an abbreviation of NEC Silicon Advanced Technology, and is a trademark of NEC Corporation.

This document outlines a typical application of this product, that is, provides an example for designing concept of an external circuit directly required for this product. NEC only assures the quality and characteristics of this product specified in this Data Sheet, and is not responsible for any user's product designs or application sets. The peripheral circuit shown in this document is just an example prepared for evaluating the operations of this product, and does not imply that the circuit configurations or constants are recommended values or regulations. In addition, these circuits are not intended for any mass-produced application sets. This is because the analog characteristics vary depending on the external parts used, mounting patterns, and other conditions. For this reason, customers are responsible for designing external circuits according to use-designed system requirements by referring this document, and should also confirm the characteristics of their application circuit before use.

No part of this document may be copied or reproduced in any form or by any means without the prior written consent of NEC Corporation. NEC Corporation assumes no responsibility for any errors which may appear in this document. NEC Corporation does not assume any liability for infringement of patents, copyrights or other intellectual property rights of third parties by or arising from use of a device described herein or any other liability arising from use of such device. No license, either express, implied or otherwise, is granted under any patents, copyrights or other intellectual property rights of NEC Corporation or of others.

M4A 96.10

CONTENTS

1. INTRODUCTION	5
2. PRODUCT LINE-UP	6
2.1 Characteristics.....	6
2.2 System Application Example	8
3. THEORETICAL DESCRIPTION	9
3.1 Description of Internal Circuits	9
3.2 Description of External Circuits.....	9
3.3 Test Circuit.....	10
4. SAMPLE APPLICATION CHARACTERISTICS.....	12
4.1 Application Characteristics for Various Matching Methods	12
4.2 Characteristics for IF Band Tuning.....	14
4.2.1 μ PC8128TB Characteristics for 130-MHz Tuning	15
4.2.2 μ PC8128TB Characteristics for 240-MHz Tuning	17
4.2.3 μ PC8151TB Characteristics for 130-MHz Tuning	19
4.2.4 μ PC8151TB Characteristics for 240-MHz Tuning	21
4.2.5 μ PC8152TB Characteristics for 130-MHz Tuning	23
4.2.6 μ PC8152TB Characteristics for 240-MHz Tuning	25
5. SUMMARY	28
6. CONCLUSION	29
APPENDIX S PARAMETER REFERENCE VALUES ($T_A = +25^\circ\text{C}$)	30

Precautions for design-ins

- (1) Observe precautions for handling because of electro-static sensitive devices.
- (2) Form a ground pattern as widely as possible to minimize ground impedance (to prevent undesired oscillation). All the ground pins must be connected together with wide ground pattern to decrease impedance difference.
- (3) The bypass capacitor should be attached to V_{CC} line.
- (4) The inductor (L) should be attached between V_{CC} pin and output pin.
The L and series capacitor (C2) values should be adjusted for applied frequency to match impedance to next stage.
- (5) The DC cut capacitor must be attached to input pin.
- (6) You should apply voltage to V_{CC} pin and output pin. You must not apply voltage to input pin nor regulate input pin voltage (e.g. direct DC pull-down).

1. INTRODUCTION

The market for mobile terminals has been expanding continuously in recent years, and as the market share of hand-held unit advances, there is a growing demand for terminals that are more compact and consume less power. In addition, recent trends concerning hand-held unit demand that the integrated circuits (ICs) used in this equipment also must become more compact and consume less power.

NEC has been selling the μ PC2714, μ PC2715, and μ PC2745 to μ PC2748 products as local buffer ICs for mobile communication systems for some time now. However, to satisfy the demands for compact size, low power consumption, and high isolation, NEC has developed and created the μ PC8128TB, μ PC8151TB, and μ PC8152TB low-current silicon microwave monolithic IC (MMIC) amplifiers to be used as various types of buffers for mobile communication systems.

These application notes introduce the features and application characteristics of these products.

See the data sheet for each product for details of the product's ratings, specifications, and usable conditions.

2. PRODUCT LINE-UP

2.1 Characteristics

Table 2-1 shows the line-up of low-current silicon MMIC amplifiers for cellular/cordless telephones.

Table 2-1. Low-Current Silicon MMIC Amplifiers for Cellular/Cordless Telephones Product Line-up
($T_A = +25^\circ\text{C}$, $V_{CC} = V_{out} = 3.0\text{ V}$, $Z_L = Z_S = 50\ \Omega$)

Part Number (Bulk Part Number)	V_{CC} (V)	I_{CC} (mA)	1.0-GHz Output Port Matching Frequency			1.66-GHz Output Port Matching Frequency			1.9-GHz Output Port Matching Frequency			Marking
			G_P (dB)	ISL (dB)	$P_{O(1\text{ dB})}$ (dBm)	G_P (dB)	ISL (dB)	$P_{O(1\text{ dB})}$ (dBm)	G_P (dB)	ISL (dB)	$P_{O(1\text{ dB})}$ (dBm)	
$\mu\text{PC8128TB}$	2.4 to 3.3	2.8	12.5	39	-4.0	13.0	39	-4.0	13.0	37	-4.0	C2P
$\mu\text{PC8151TB}$		4.2	12.5	38	+2.5	15.0	36	+1.5	15.0	34	+0.5	C2U
$\mu\text{PC8152TB}$		5.6	23.0	40	-4.5	19.5	36	-8.5	17.5	35	-8.5	C2V

Remark The above values are typical values for major characteristics. See each product's data sheet for detailed ratings and characteristic, etc.

This line-up achieves low-current consumption, high efficiency, and high gain with the power supply voltage in the 3-V range. The low circuit current consumption is approximately 40% of the 5 to 7.5 mA consumed by the existing μPC2745 to μPC2748 products. These products use a 6-pin mini mold package of size 2012. Figure 2-1 shows external views of this package (package drawing).

Due to limited printing space on these mini mold ICs, a three-character is marked instead of part number shown on the molds. Each three-character marking corresponds to a different part number. Due to space limitations, the pin 1 mark is printed on the bottom side. Figure 2-2 shows a marking example of these products.

Taping is used as the supplying form for all products and the part number is "Bulk part No. - taping code." For details, refer to the data sheet.

All ICs in this product line-up have been developed and manufactured using NEC's proprietary NESAT™ III silicon bipolar process. For details about this process, refer to the pamphlet entitled "NESAT Process pamphlet" (Document No. P12647E).

Figure 2-1. Package Drawing of 6-Pin Super Mini-Mold Low-Current Silicon MMIC Amplifiers

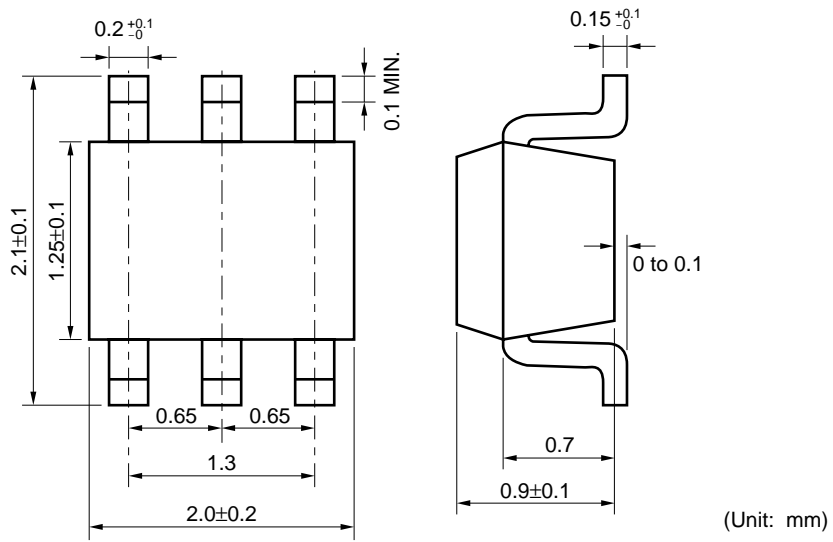
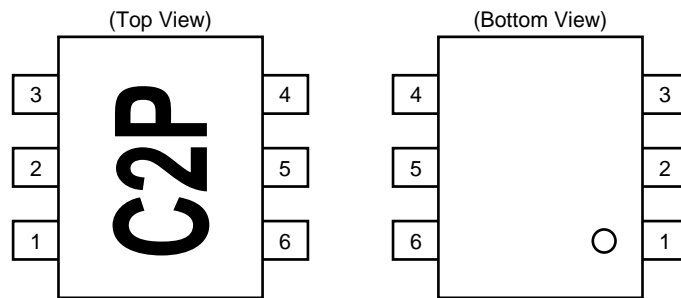

Figure 2-2. Exterior of the Marking Example



Remark The marking example shown in the above figure corresponds to μ PC8128TB.

2.2 System Application Example

Figure 2-3 shows a system block diagram that can be considered as an application example of these ICs due to system requirement characteristics.

Figure 2-3. System Block Diagram

Location examples in digital cellular

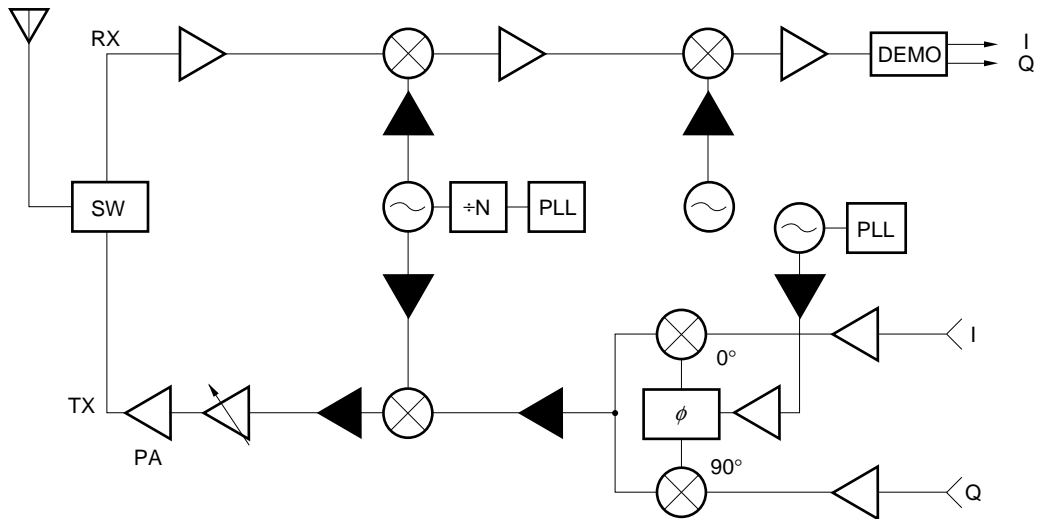

These ICs can be added to your system around \blacktriangle parts, when you need more isolation or gain. The application herein, however, shows only examples, therefore the application can depend on your kit evaluation.

3. THEORETICAL DESCRIPTION

3.1 Description of Internal Circuits

The μ PC8128TB and μ PC8151TB have simple two-stage configurations without negative feedback. The μ PC8152TB incorporates 50- Ω matching circuit formed by resistors on the input side. A multiple negative feedback circuit is provided to offset the variations between HFE and resistance. To obtain desired RF characteristics, a two-stage configuration is employed. Figure 3-1 shows an internal equivalent circuit.

The output pins of the ICs in this product line-up are used to constitute matching circuits externally, and low current consumption is achieved due to open collector output of the output-stage transistor and by high impedance output. For the bias to the output pins, the same voltage as the V_{cc} is applied via the inductor of the matching circuit.

Figure 3-1. Internal Equivalent Circuits of Low-Current Silicon MMIC Amplifiers

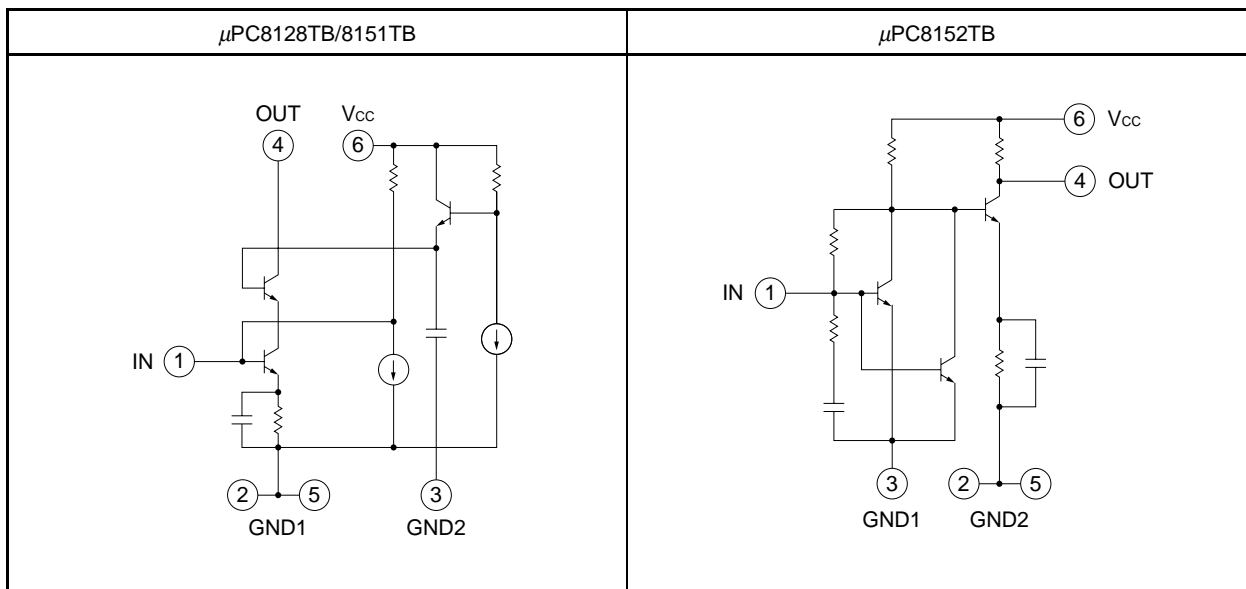

3.2 Description of External Circuits

External Circuit Configuration

By attaching an external inductor to the output pin, the ICs in this product line-up can achieve low-current consumption that could not be obtained by conventional internal 50- Ω wideband matching ICs. Therefore, a narrowband matching circuit should be configured by using an LC externally attached to the output pin to suit the usage frequency. Also, since the μ PC8128TB or μ PC8151TB does not have an on-chip 50- Ω matching circuit based on the resistance of the IC's input stage, the input stage return loss increases. To improve the input stage return loss of the μ PC8128TB or μ PC8151TB, a narrowband matching circuit that suits the usage frequency is also required at the input stage.

The following three external circuit configurations can be considered according to the differences of the matching circuits.

- <1> Output isolation matching (no matching for the input stage, and an output stage return loss optimized to approximately 10 to 20 dB)
- <2> Output 50- Ω matching (no matching for the input stage, and matching of the output stage to 50 Ω)
- <3> Input/output 50- Ω matching (matching both of the input and output stages to 50 Ω)

Design Method

For <2> and <3> above, the 50- Ω matching circuit of the LC should be designed based on the S parameter of the IC while also taking into account mounting circuit board elements. However, for <1>, since definite points cannot be represented on a Smith chart, the following procedure must be used to adjust the values.

- First, match the output stage to 50 Ω for a standard.
- Next, while using a network analyzer to monitor S12, adjust the mounting position and constants of the externally attached circuit (LC) so that the isolation can be excellent.

At NEC, excellent isolation was obtained when this procedure was used to adjust the output stage return loss to the range of 10 to 20 dB.

The circuit constants that appear in these application notes and the data sheets are values for the corresponding evaluation boards. Since the evaluation boards, which are designed for simple evaluation, occupy considerable space, they cannot be applied directly in an actual system. The S parameter values (MAG and ANG) and input/output Smith charts of the ICs themselves are included in the data sheets and in the appendix of this document for reference by users of matching circuit design. Users should optimize the matching circuit constants by referring to this explanation and carefully considering these parameters and the mounting circuit board elements.

The characteristic curves that appear in the data sheets were measured by creating a matching circuit that emphasizes isolation (<1> Isolation matching). For characteristics in the circuit configurations of <2> and <3>, see **Table 4-1 Measurement Results** in **4.1 Application Characteristics for Various Matching Methods**.

3.3 Test Circuit

To measure the electrical specifications described in the data sheet, a test circuit was used in which a matching circuit was created by an LC at the output pin. Figure 3-2 shows the test circuit used for these ICs, and Figure 3-3 shows the evaluation board layout.

Figure 3-2. Test Circuit

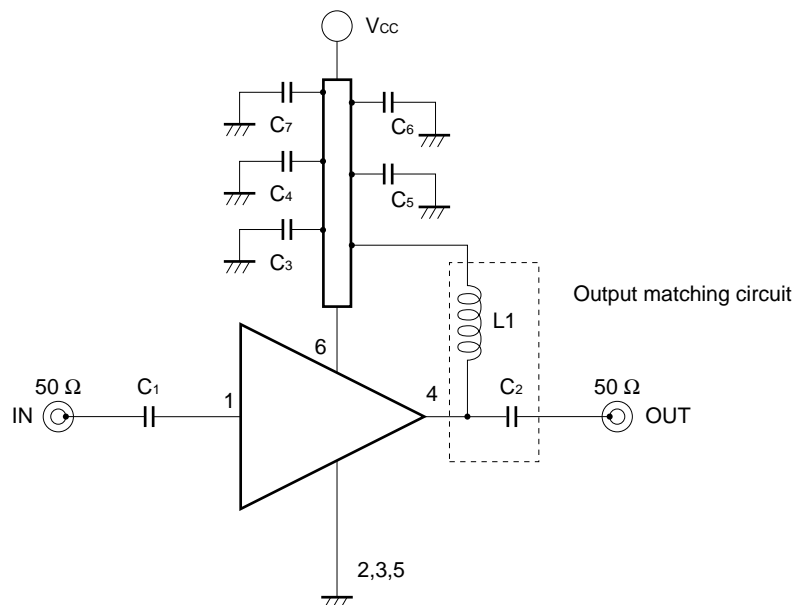

This test circuit is used in an NEC measurement jig. Multiple bypass capacitors are used in the V_{CC} line due to the board pattern design of the NEC jig. The number of bypass capacitors should be reduced by optimizing the circuit board pattern when performing an actual application.

Figure 3-3. Evaluation Board for μ PC8128TB, μ PC8151TB, and μ PC8152TB

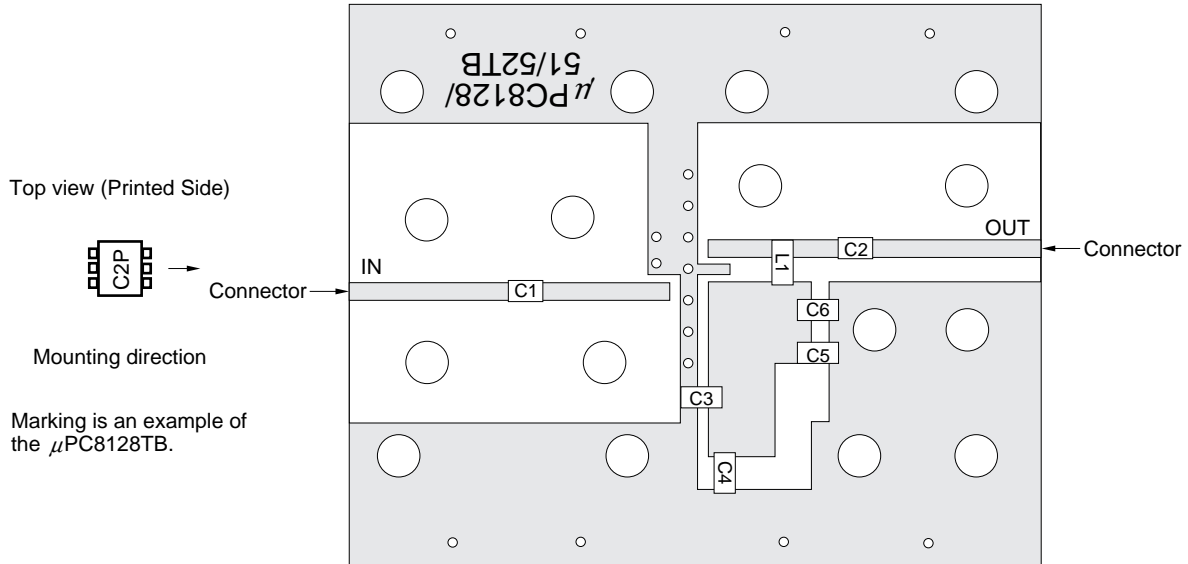

Notes regarding board examples

- Board material -----Double-sided copper clad polyamide board is used to reduce loss due to the board.
- Back side -----Entire side is ground pattern. Through holes are used to ensure proper grounding for IC mounting side.
- Specifications-----Board dimensions: 42 × 35 × 0.4 mm, with 35- μ m thick copper patterning on both sides.

4. SAMPLE APPLICATION CHARACTERISTICS

4.1 Application Characteristics for Various Matching Methods

The ICs in this line-up were turned in a narrow band to a usage frequency within the recommended operating frequency range (100 to 1900 MHz). This section introduces the results of evaluating the characteristics for each matching method.

These evaluations were performed according to each of the three matching methods, namely output isolation matching (matching for which isolation is best), output 50-Ω matching, and input/output 50-Ω matching, at frequencies of 1.0, 1.66, and 1.9 GHz, using the μPC8128TB. Table 4-1 shows the evaluation results and Figure 4-1 shows the measurement circuits.

The isolation and noise figure values were better for the output isolation matching method than for the other matching methods. Since the output return loss and input return loss are improved for the output 50-Ω matching and input/output 50-Ω matching methods, the power gain becomes 1 to 2 dB higher than for the output isolation matching method. However, the isolation and noise figure results were worse. These evaluation results indicate that when isolation and noise figure characteristics are emphasized, the output isolation matching method is optimum, but when power gain is emphasized even if the isolation and noise figure are made somewhat worse, the methods that match the output and input stages to 50 Ω are optimum. The points at which isolation was best in these evaluation results (output isolation matching) were obtained by setting the output return loss in the 10 to 20 dB range.

These evaluations were also performed for the μPC8151TB using the same internal circuits as were used for the μPC8128TB, and similar results were obtained.

Table 4-1. Measurement Results

Test Conditions: $T_A = +25^\circ\text{C}$, $V_{CC} = V_{out} = 3.0\text{ V}$, $Z_L = Z_s = 50\ \Omega$

1.0-GHz Tuning

Matching Method	Input Return Loss S11 (dB)	Output Return Loss S22 (dB)	Power Gain S21 (dB)	Isolation S12 (dB)	Noise Figure NF (dB)
Output isolation	4.6	15.3	11.7	37.3	5.9
Output 50 Ω	4.6	35.1	12.0	36.7	6.0
Input/output 50 Ω	30.7	27.3	13.6	34.9	6.6

1.66-GHz Tuning

Matching Method	Input Return Loss S11 (dB)	Output Return Loss S22 (dB)	Power Gain S21 (dB)	Isolation S12 (dB)	Noise Figure NF (dB)
Output isolation	5.8	16.6	11.0	41.2	5.9
Output 50 Ω	6.3	26.5	11.0	37.8	6.0
Input/output 50 Ω	30.8	27.6	12.1	35.2	6.7

1.9-GHz Tuning

Matching Method	Input Return Loss S11 (dB)	Output Return Loss S22 (dB)	Power Gain S21 (dB)	Isolation S12 (dB)	Noise Figure NF (dB)
Output isolation	6.0	11.6	11.1	38.3	5.9
Output 50 Ω	6.3	33.1	11.9	36.2	6.0
Input/output 50 Ω	31.7	29.8	12.0	35.5	7.0

Figure 4-1. Test Circuits

(1) Output isolation matching circuit

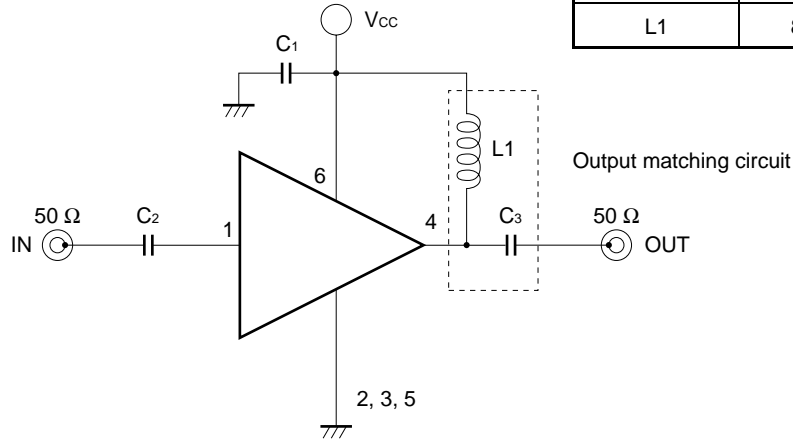

Component List

	1.0-GHz Tuning	1.66-GHz Tuning	1.9-GHz Tuning
C ₁ , C ₂	1 000 pF	1 000 pF	1 000 pF
C ₃	1.0 pF	0.7 pF	0.5 pF
L1	8.2 nH	3.3 nH	1.8 nH

(2) Output 50-Ω matching circuit

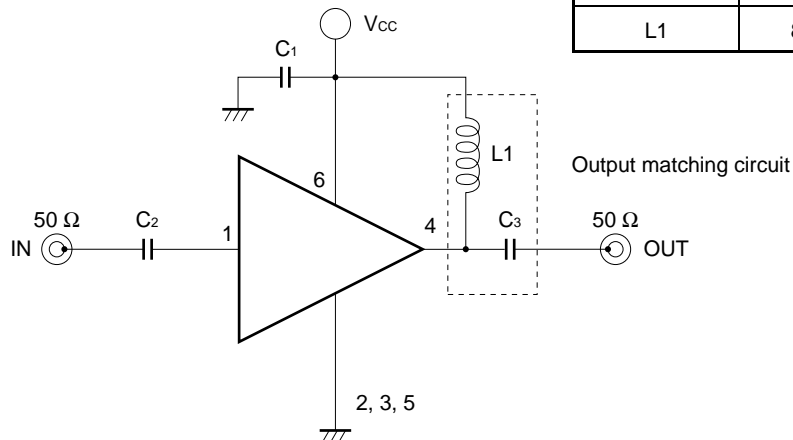

Component List

	1.0-GHz Tuning	1.66-GHz Tuning	1.9-GHz Tuning
C ₁ , C ₂	1 000 pF	1 000 pF	1 000 pF
C ₃	0.8 pF	0.7 pF	0.6 pF
L1	8.2 nH	3.3 nH	1.7 nH

Notes: Used parts for this evaluations
 C: Murata's size 1608 chip capacitor
 L: TOKO's LL2012 Multilayer chip inductor

(3) Input/output 50-Ω matching circuit

Component List

	1.0-GHz Tuning	1.66-GHz Tuning	1.9-GHz Tuning
C ₁	1 000 pF	1 000 pF	1 000 pF
C ₂	1.0 pF	1.5 pF	1.5 pF
C ₃	1 000 pF	1 000 pF	1 000 pF
C ₄	0.8 pF	0.7 pF	0.6 pF
L ₁	10 nH	1.5 nH	2.7 nH
L ₂	8.2 nH	3.3 nH	1.7 nH

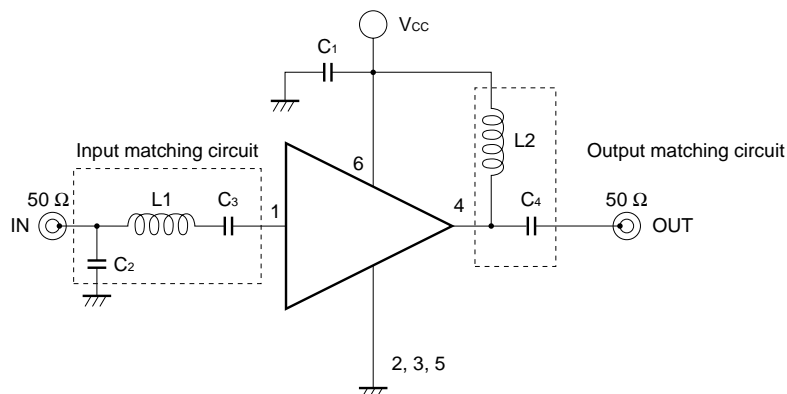

4.2 Characteristics for IF Band Tuning

Although the ICs in this line-up were developed as various types of buffer amplifiers for cellular or cordless telephones, the recommended operating frequency range is 100 to 1900 MHz, and these ICs can also be used at IF-band frequencies. For this section, the characteristics were measured for input/output tunings at operating frequencies of 130 MHz and 240MHz, which are used frequently in the IF band. Table 4-2 shows the measurement results, and Figure 4-2 shows the measurement circuits. When these ICs were used in the IF band, the power gain was higher and the isolation was better than when they were used in the 1 to 2 GHz range.

Table 4-2. Measurement Results

Test Conditions: $T_A = +25^\circ\text{C}$, $V_{CC} = V_{out} = 3.0\text{ V}$, $Z_L = Z_S = 50\ \Omega$

130-MHz Input/Output Tuning (Output Tuning Only for the $\mu\text{PC8152TB}$)

Part No.	Input Return Loss S11 (dB)	Output Return Loss S22 (dB)	Power Gain S21 (dB)	Isolation S12 (dB)	Noise Figure NF (dB)
$\mu\text{PC8128TB}$	30.8	10.2	17.9	41.5	6.1
$\mu\text{PC8151TB}$	29.4	11.6	18.7	42.5	6.3
$\mu\text{PC8152TB}$	26.7	18.8	19.7	51.8	3.1

240-MHz Input/Output Tuning (Output Tuning Only for the $\mu\text{PC8152TB}$)

Part No.	Input Return Loss S11 (dB)	Output Return Loss S22 (dB)	Power Gain S21 (dB)	Isolation S12 (dB)	Noise Figure NF (dB)
$\mu\text{PC8128TB}$	37.9	32.3	16.9	36.1	6.2
$\mu\text{PC8151TB}$	22.3	29.3	16.4	37.3	6.5
$\mu\text{PC8152TB}$	25.5	21.8	20.2	48.2	3.2

4.2.1 μ PC8128TB Characteristics for 130-MHz Tuning

Conditions: $T_A = +25^\circ\text{C}$, $V_{CC} = V_{out} = 3.0\text{ V}$, $Z_L = Z_S = 50\ \Omega$

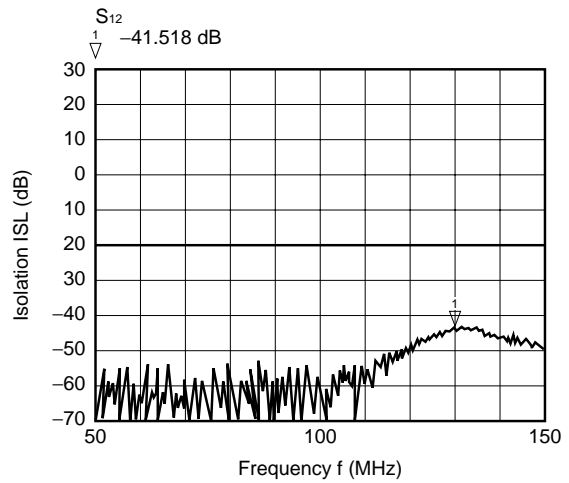
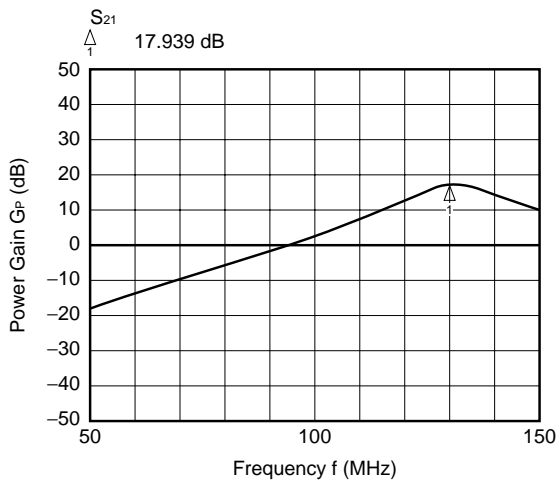
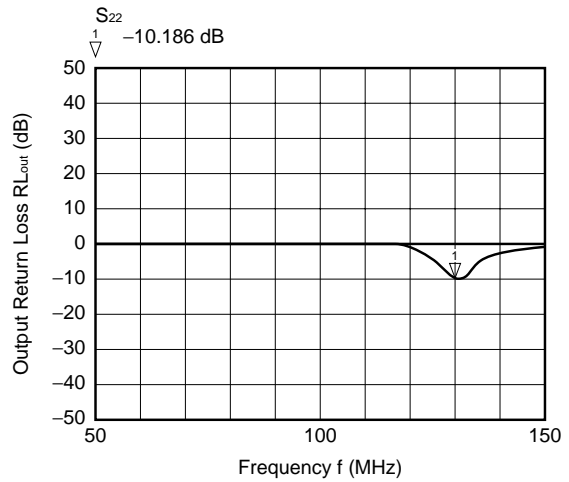
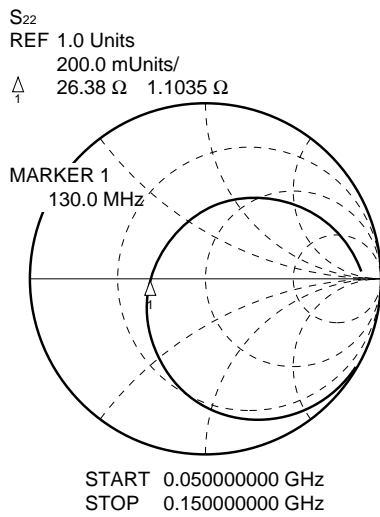
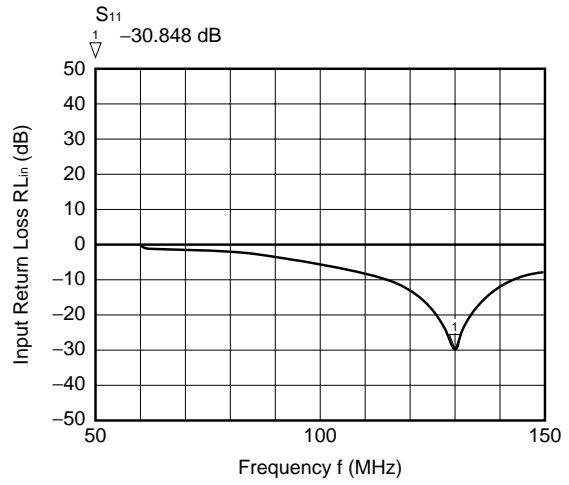
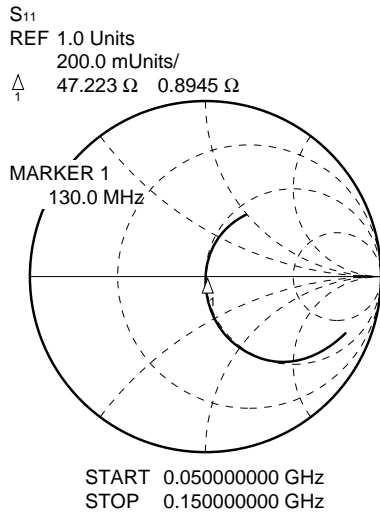

μ PC8128TB Characteristics for 130-MHz Tuning

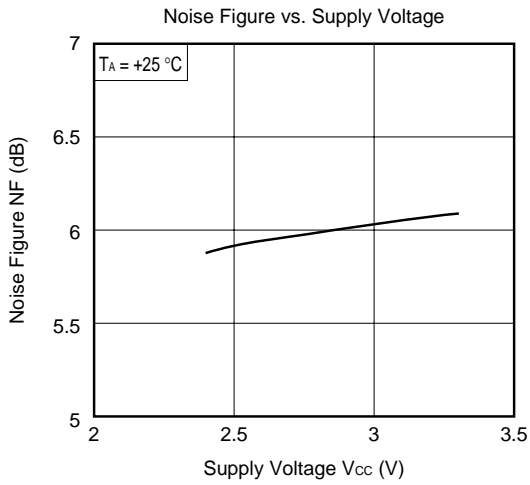
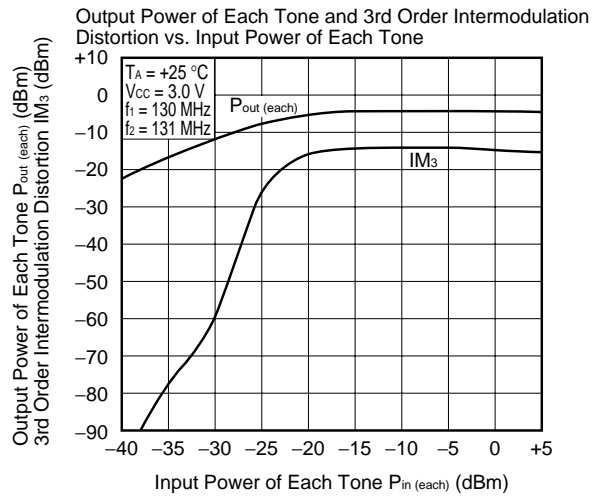
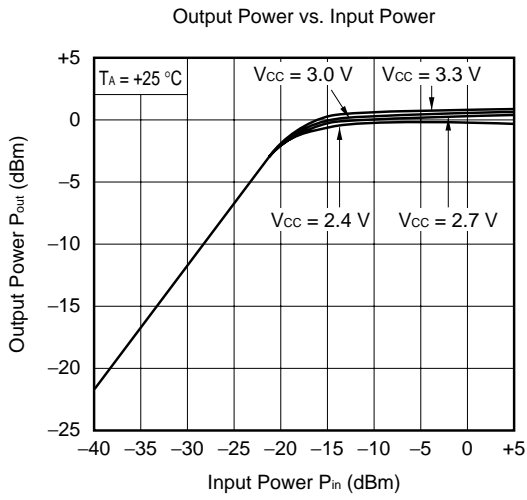

4.2.2 μ PC8128TB Characteristics for 240-MHz Tuning

Conditions: $T_A = +25^\circ\text{C}$, $V_{CC} = V_{out} = 3.0\text{ V}$, $Z_L = Z_S = 50\ \Omega$

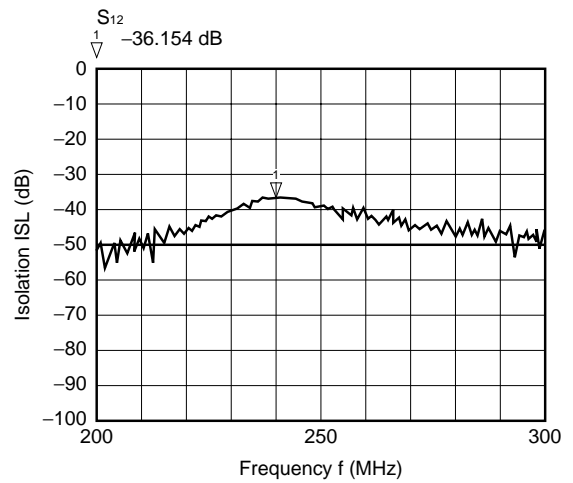
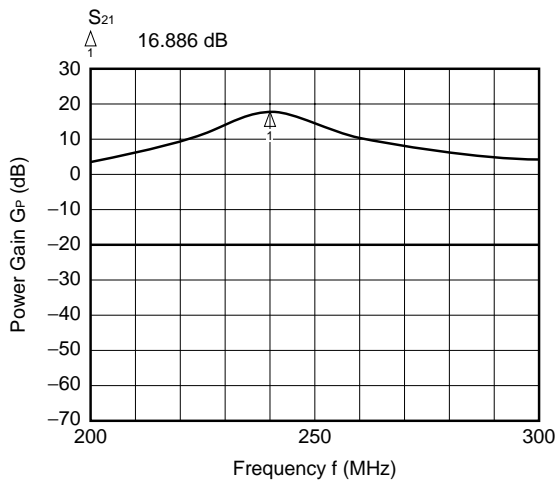
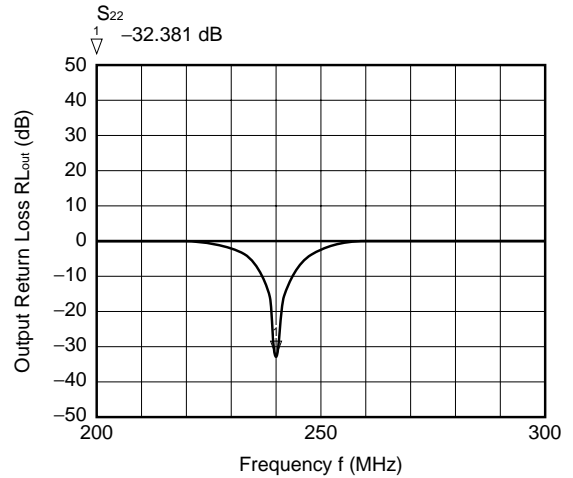
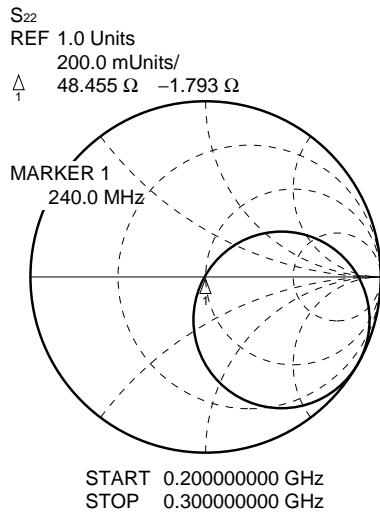
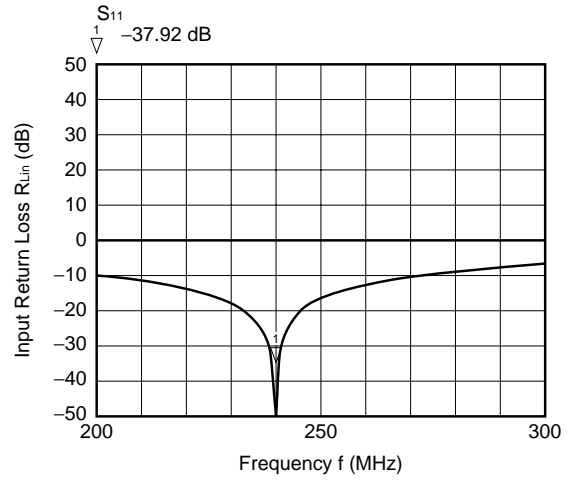
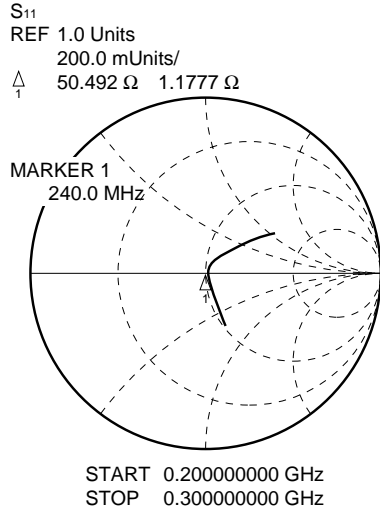

μPC8128TB Characteristics for 240-MHz Tuning

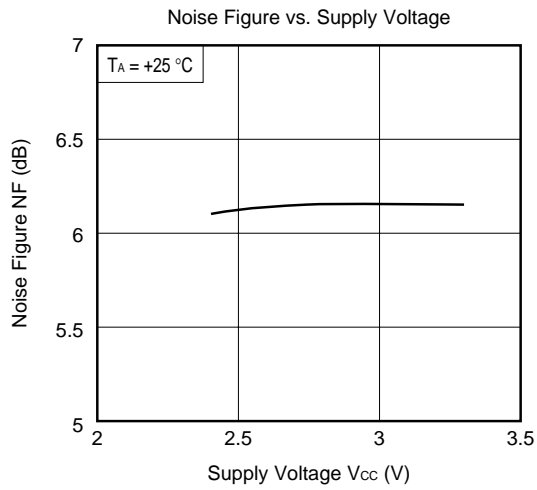
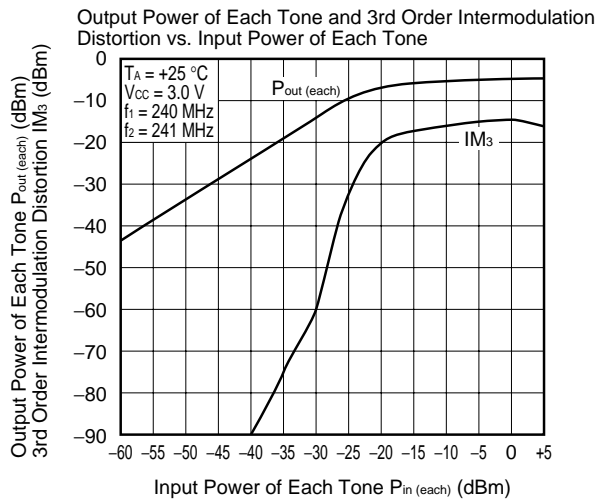
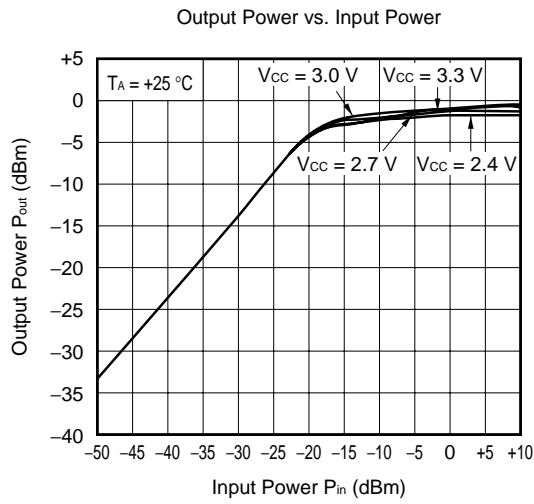

4.2.3 μ PC8151TB Characteristics for 130-MHz Tuning

Conditions: $T_A = +25^\circ\text{C}$, $V_{CC} = V_{out} = 3.0\text{ V}$, $Z_L = Z_S = 50\ \Omega$

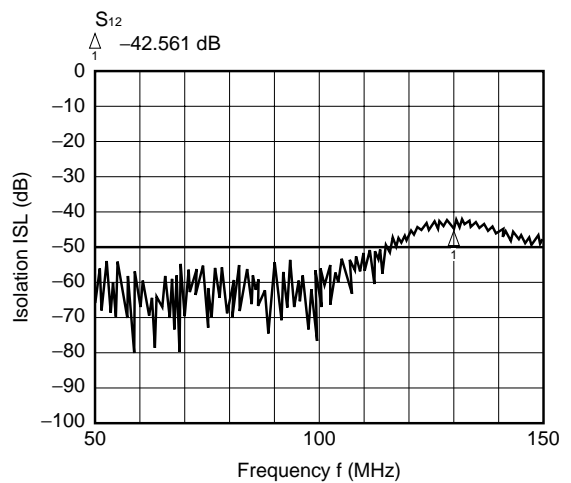
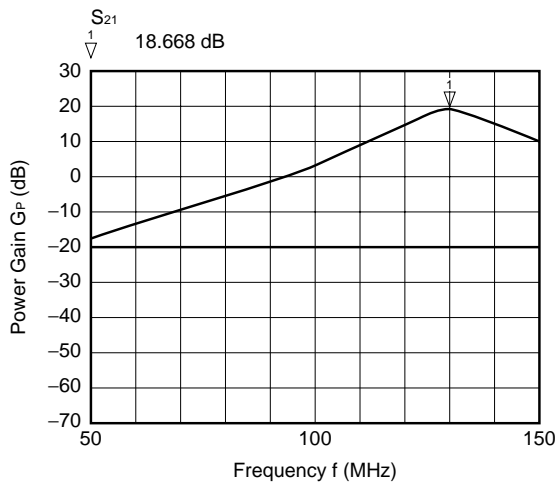
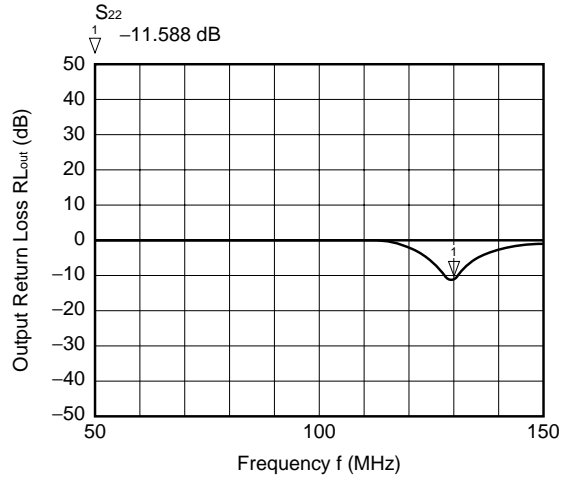
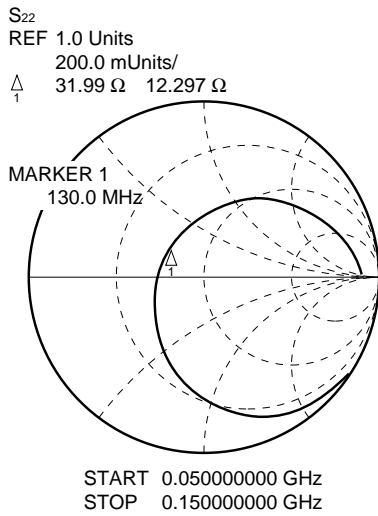
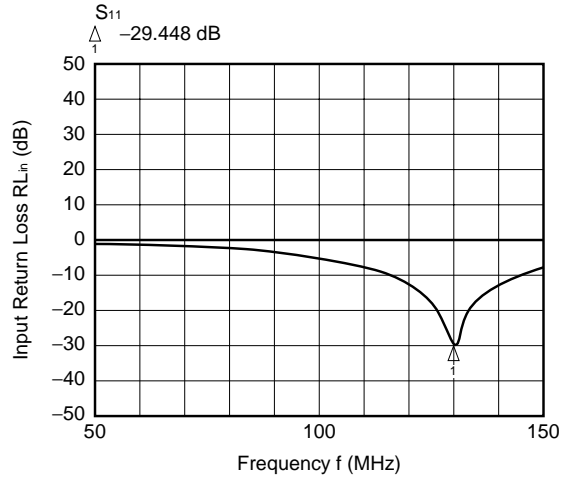
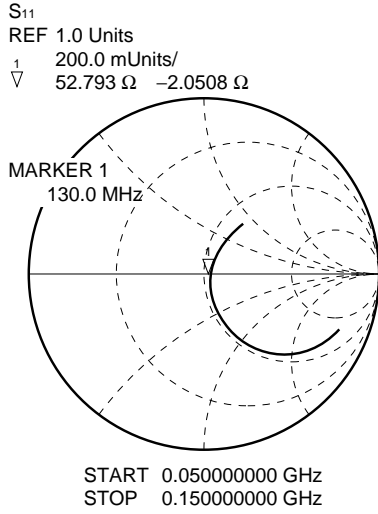

μPC8151TB Characteristics for 130-MHz Tuning

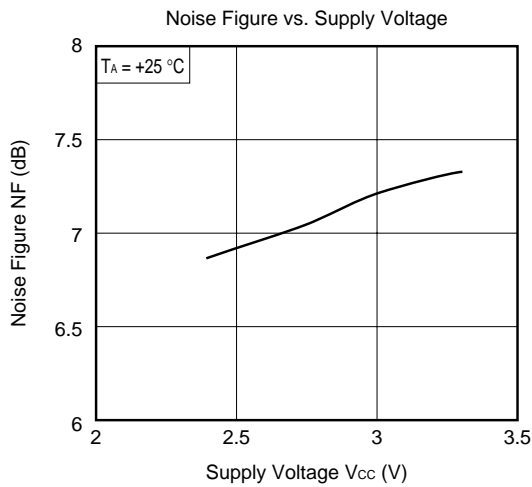
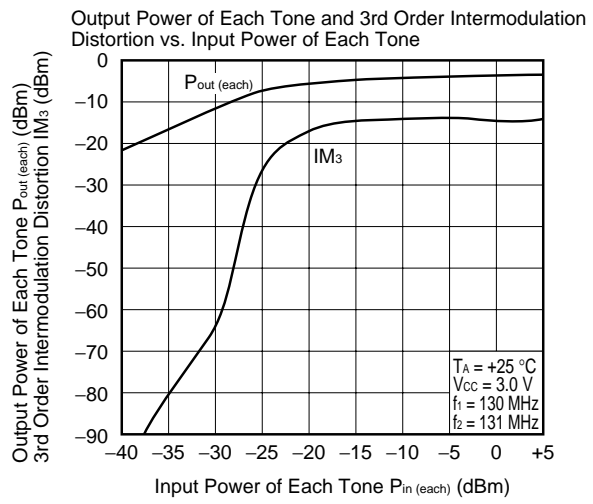
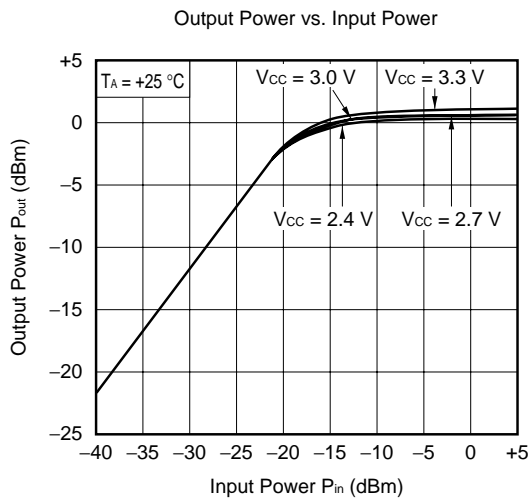

4.2.4 μ PC8151TB Characteristics for 240-MHz Tuning

Conditions: $T_A = +25^\circ\text{C}$, $V_{CC} = V_{out} = 3.0\text{ V}$, $Z_L = Z_S = 50\ \Omega$

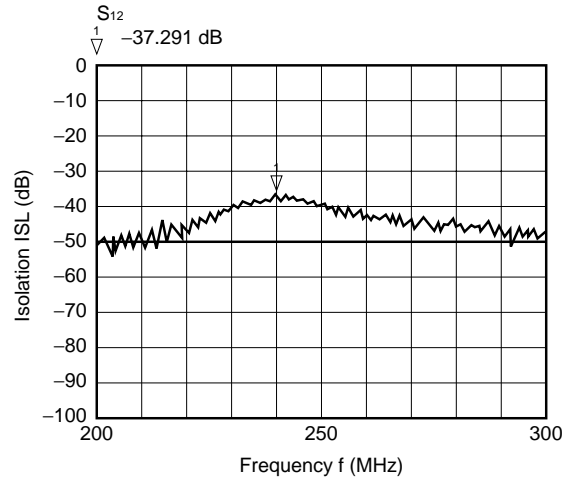
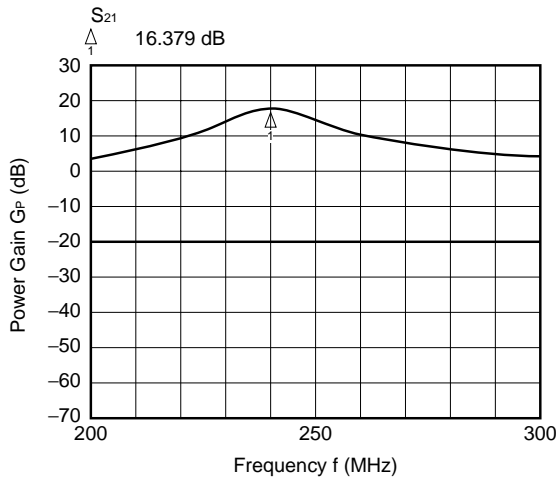
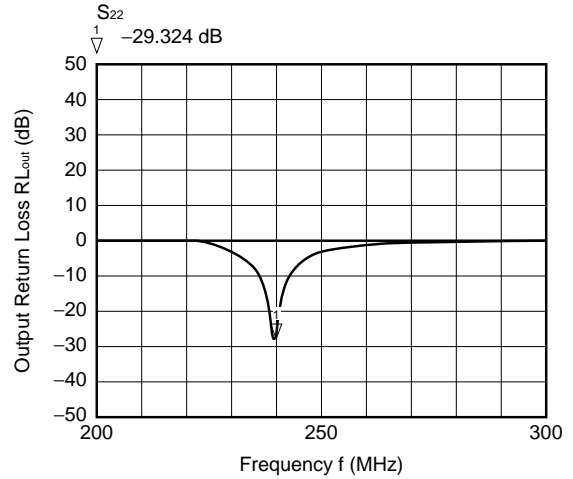
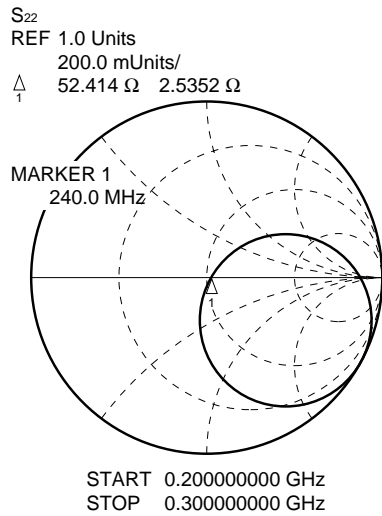
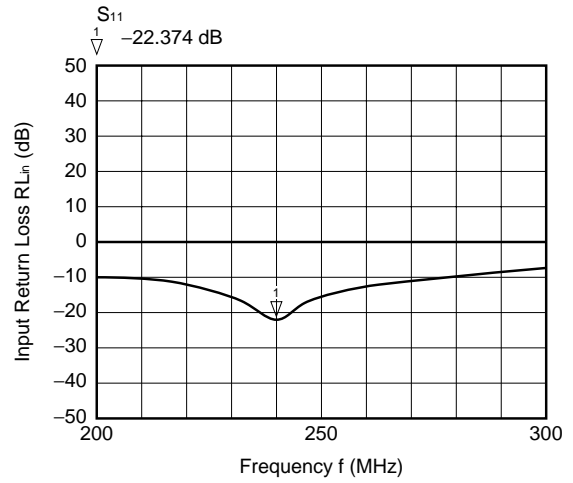
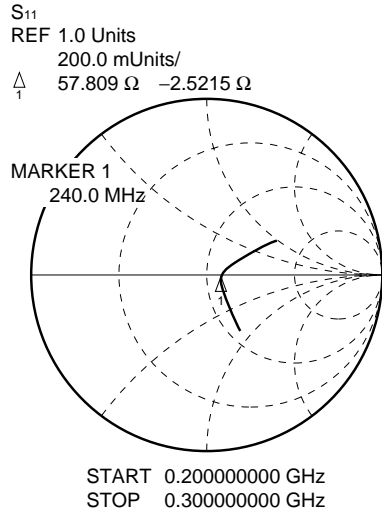

μ PC8151TB Characteristics for 240-MHz Tuning

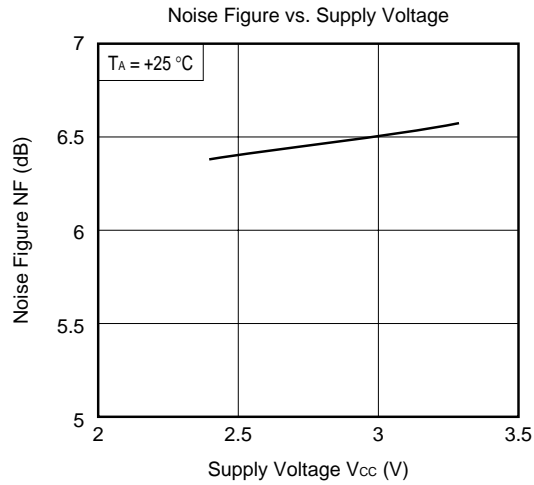
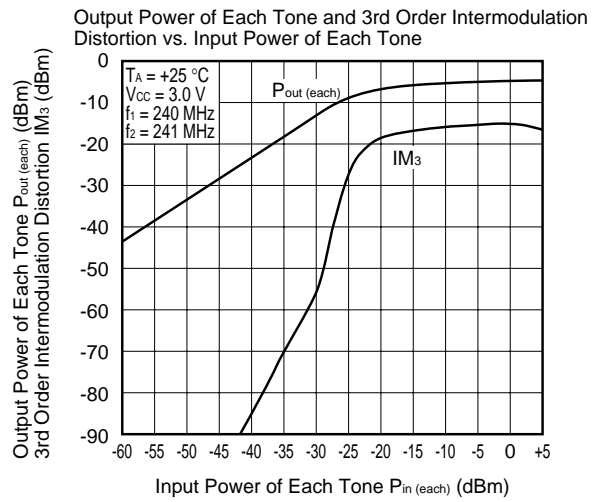
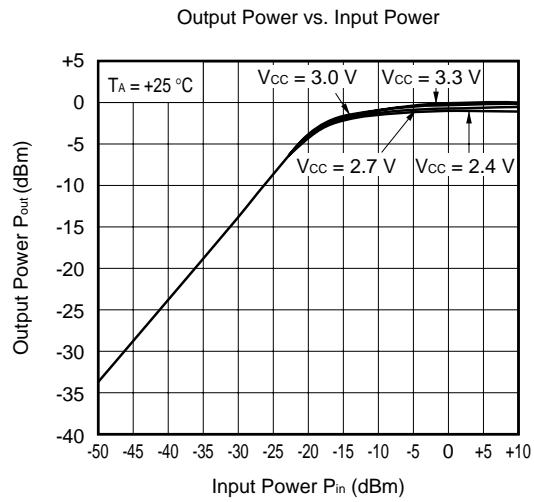

4.2.5 μ PC8152TB Characteristics for 130-MHz Tuning

Conditions: $T_A = +25^\circ\text{C}$, $V_{CC} = V_{out} = 3.0\text{ V}$, $Z_L = Z_S = 50\ \Omega$

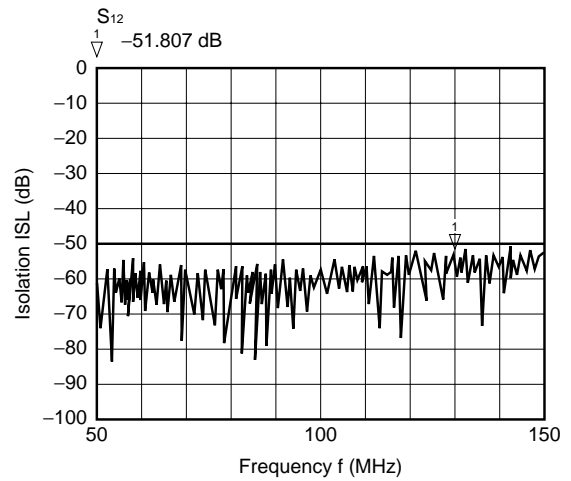
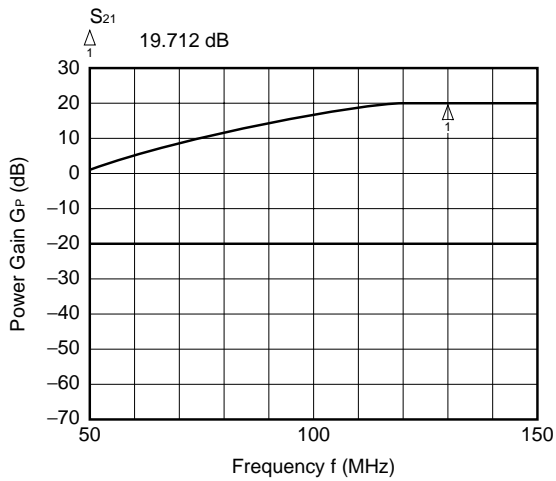
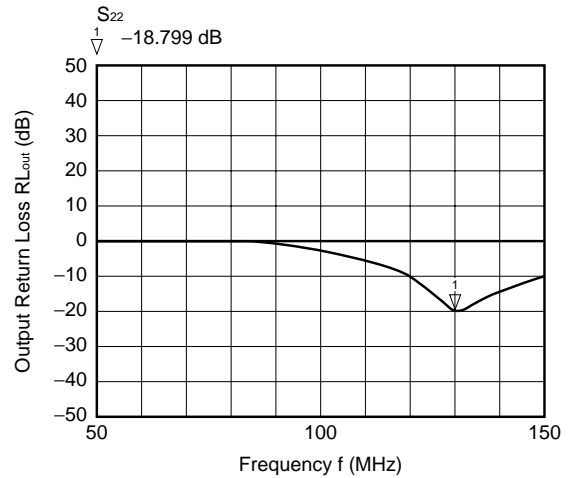
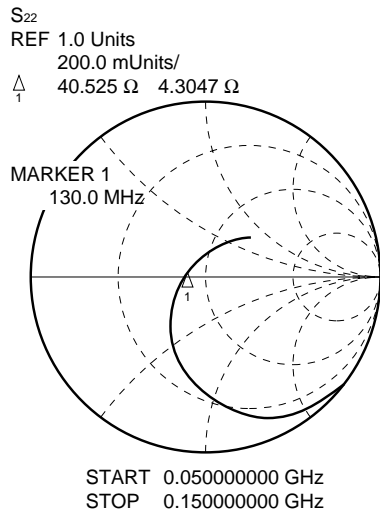
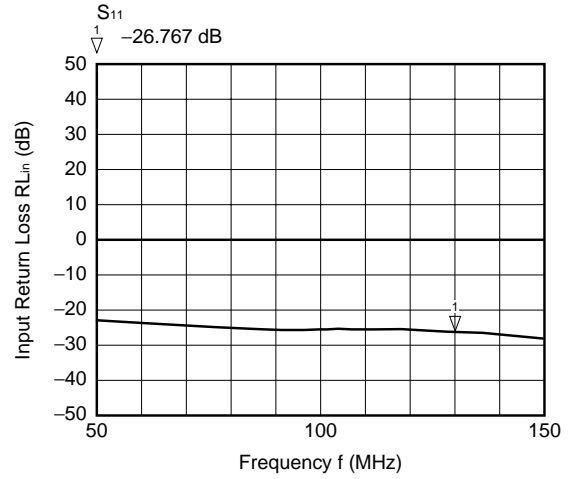
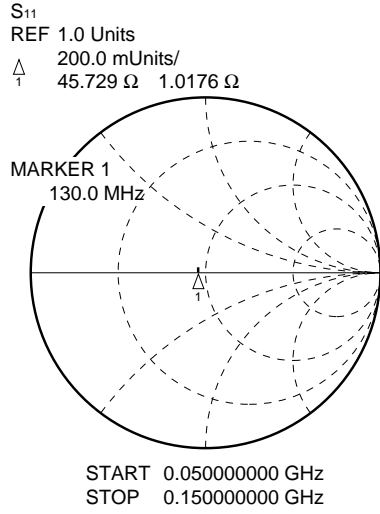

μ PC8152TB Characteristics for 130-MHz Tuning

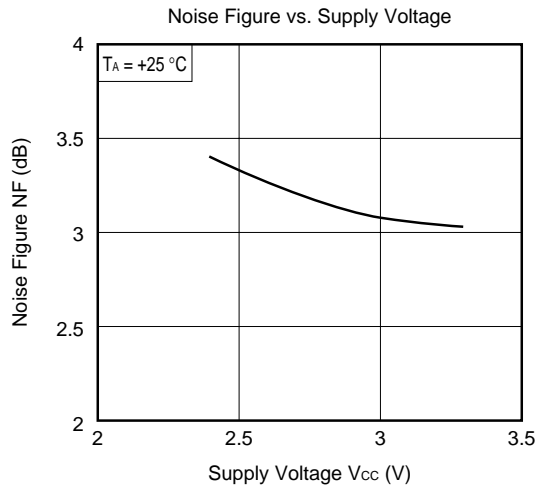
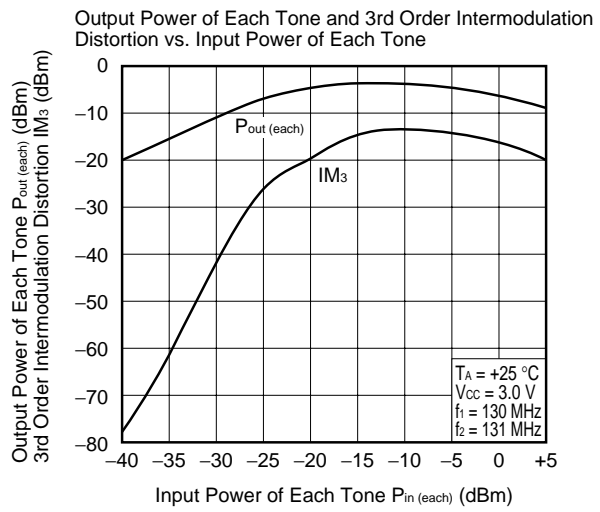
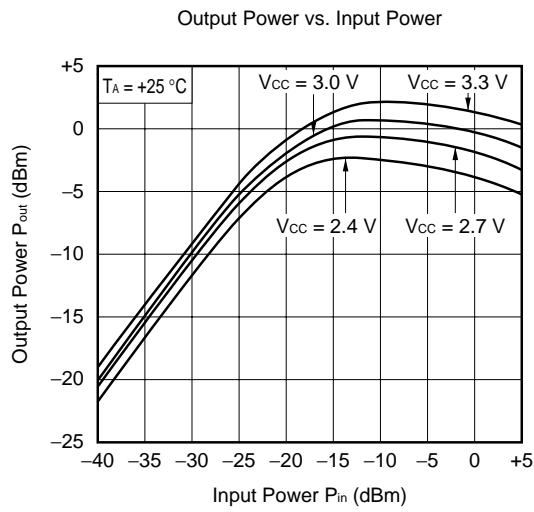

4.2.6 μ PC8152TB Characteristics for 240-MHz Tuning

Conditions: $T_A = +25^\circ\text{C}$, $V_{CC} = V_{out} = 3.0\text{ V}$, $Z_L = Z_S = 50\ \Omega$

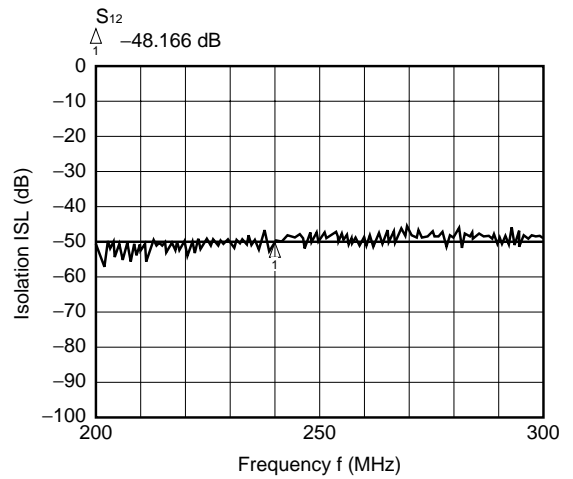
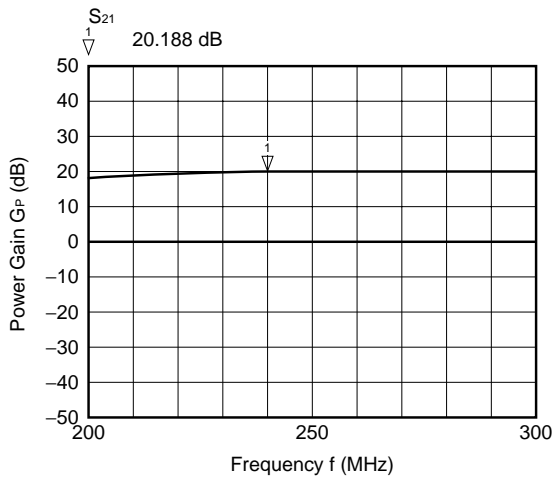
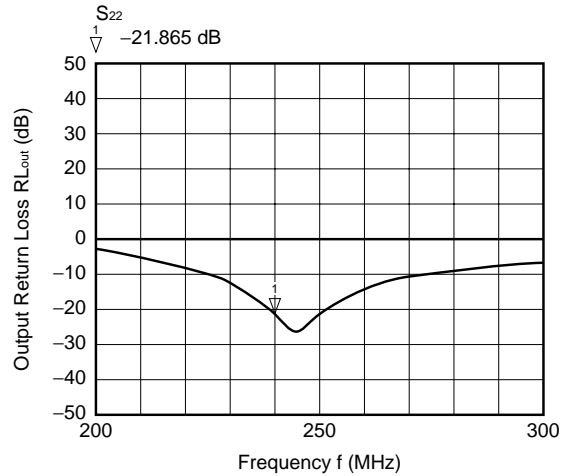
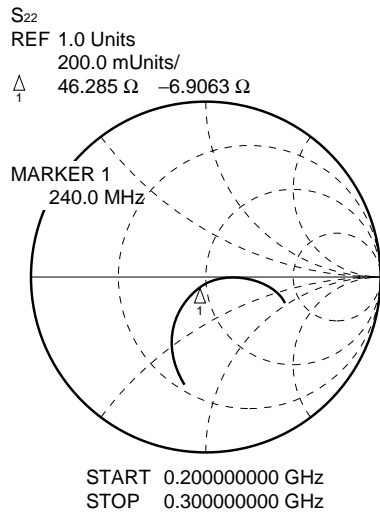
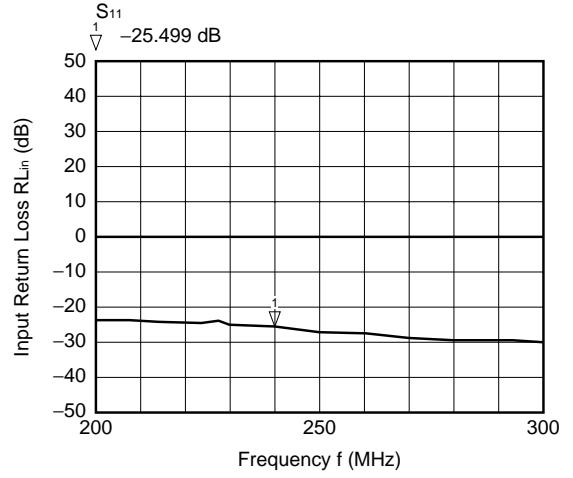
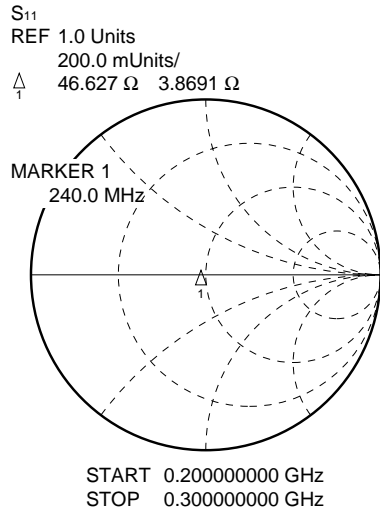

μPC8152TB Characteristics for 240-MHz Tuning

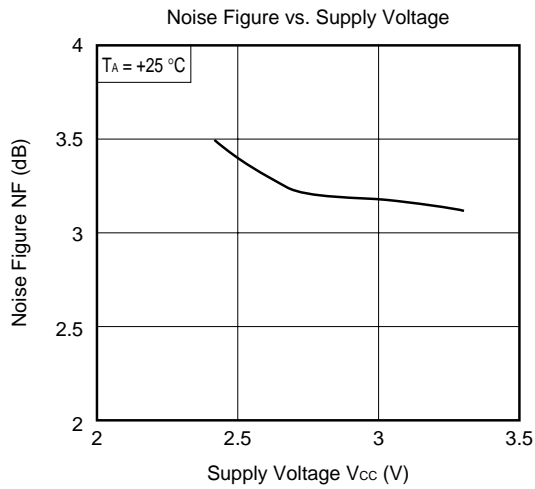
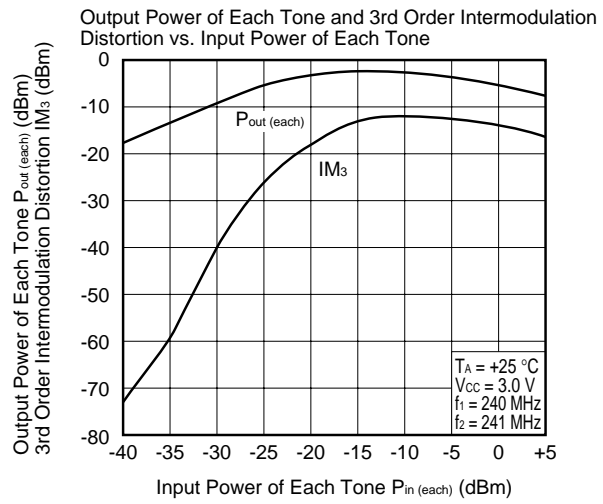
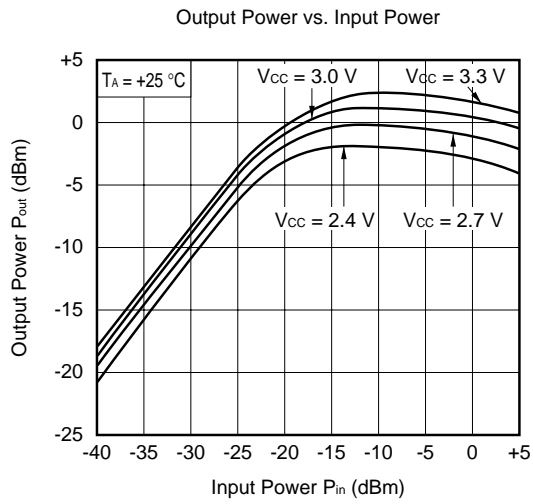
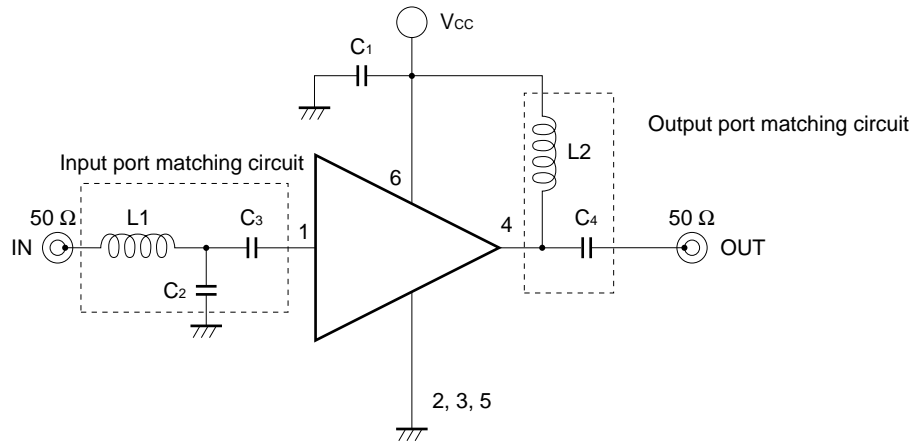

Figure 4-2. Test Circuits

(1) μ PC8128TB/ μ PC8151TB



Component List

	130-MHz Input/Output Tuning	240-MHz Input/Output Tuning
C ₁	1 000 pF	1 000 pF
C ₂	2.5 pF	0.5 pF
C ₃	200 pF	1 000 pF
C ₄	3.5 pF	1.5 pF
L ₁	180 nH	83 nH
L ₂	270 nH	120 nH

(2) μ PC8152TB

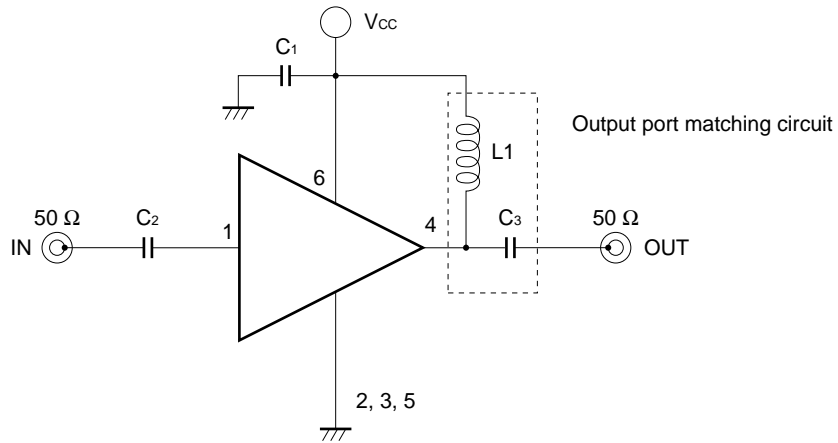

Component List

	130-MHz Input/Output Tuning	240-MHz Input/Output Tuning
C ₁ , C ₂	1 000 pF	1 000 pF
C ₃	12 pF	5 pF
L ₁	135 nH	68 nH

5. SUMMARY

Table 5-1. External Circuit Configuration and Characteristics

External Circuit Configuration	Main Characteristic Change	Emphasized Characteristic
Output isolation matching (no matching for the input stage, and an output stage return loss optimized to approximately 10 to 20 dB)	Isolation and noise figure are better than for the output 50-Ω matching and input/output 50-Ω matching methods.	Isolation and noise figure are emphasized
Output 50-Ω matching (no matching for the input stage)	As compared with the output isolation matching method, power gain increases by approximately 1 dB. Isolation worsens by approximately 2 dB.	Power gain and noise figure are emphasized.
Input/output 50-Ω matching	As compared with the output isolation matching method, power gain increases by approximately 2 dB. Isolation worsens by approximately 3 dB. Noise figure worsens by approximately 1 dB.	Power gain is emphasized.

6. CONCLUSION

These application notes explained the characteristics of application circuits using the μ PC8128TB, μ PC8151TB, and μ PC8152TB, which are a series of low-current silicon MMIC amplifiers for cellular/cordless telephones, and presented examples for selecting these ICs.

We hope that these application notes will be of some assistance to you when you use these silicon MMICs.

References

- Data sheets for each product
 - μ PC8128TB, μ PC8151TB, μ PC8152TB (Document No. P12549E)
 - μ PC2745TB, μ PC2746TB (Document No. P11511E)
 - μ PC2747TB, μ PC2748TB (Document No. P13444E)

- Application Notes
 - Usage and Applications of 6-Pin Mini-mold, 6-Pin Super Mini-mold Silicon High-Frequency Wideband Amplifier MMIC (Document No. P11976E)

APPENDIX S PARAMETER REFERENCE VALUES (T_A = +25°C)

μPC8128TB

V_{CC} = V_{out} = 3.0 V, I_{CC} = 2.8 mA

FREQUENCY MHz	S ₁₁		S ₂₁		S ₁₂		S ₂₂	
	MAG	ANG	MAG	ANG	MAG	ANG	MAG	ANG
100.0000	.859	-14.5	1.089	-176.0	.001	176.7	1.005	-1.7
200.0000	.769	-23.8	1.138	-173.2	.001	142.6	1.019	-4.2
300.0000	.694	-27.1	1.208	-171.0	.003	112.3	1.015	-5.8
400.0000	.637	-30.1	1.336	-171.7	.005	88.8	.996	-8.7
500.0000	.595	-32.4	1.478	-172.8	.005	77.7	.976	-10.9
600.0000	.568	-35.9	1.623	-175.6	.005	64.1	.976	-12.8
700.0000	.555	-40.7	1.822	-179.0	.006	73.7	.983	-14.1
800.0000	.569	-45.0	1.955	176.9	.007	64.2	.988	-15.5
900.0000	.597	-49.4	2.147	172.5	.007	72.5	.973	-17.4
1000.0000	.633	-52.6	2.307	166.8	.008	49.9	.945	-19.9
1100.0000	.643	-56.3	2.468	160.6	.008	66.8	.928	-22.0
1200.0000	.644	-59.7	2.572	153.6	.007	48.8	.934	-24.1
1300.0000	.611	-64.3	2.677	144.2	.007	45.3	.950	-24.8
1400.0000	.585	-69.5	2.704	137.3	.005	64.5	.938	-26.6
1500.0000	.562	-75.1	2.693	128.8	.005	66.0	.913	-28.2
1600.0000	.559	-80.5	2.712	122.7	.005	93.6	.898	-30.1
1700.0000	.547	-85.4	2.640	116.3	.006	83.5	.892	-32.0
1800.0000	.540	-89.5	2.665	110.4	.005	101.6	.893	-33.6
1900.0000	.524	-93.2	2.599	104.5	.005	115.4	.896	-34.7
2000.0000	.503	-97.8	2.582	98.5	.006	110.9	.895	-36.5
2100.0000	.474	-103.5	2.500	93.1	.007	129.4	.877	-38.6
2200.0000	.461	-110.0	2.472	86.7	.008	130.5	.873	-40.4
2300.0000	.465	-116.2	2.453	80.9	.009	137.8	.878	-41.9
2400.0000	.475	-121.0	2.426	74.8	.010	133.3	.877	-43.5
2500.0000	.488	-123.1	2.364	70.4	.012	139.0	.871	-45.4
2600.0000	.491	-125.0	2.310	63.9	.011	140.8	.864	-47.9
2700.0000	.480	-125.1	2.282	61.1	.014	142.6	.855	-51.1
2800.0000	.460	-127.0	2.159	56.3	.014	140.7	.851	-53.0
2900.0000	.437	-129.4	2.205	51.4	.016	141.5	.867	-55.1
3000.0000	.410	-133.4	2.085	48.8	.018	143.2	.861	-57.0
3100.0000	.401	-137.8	2.038	42.4	.019	142.1	.855	-60.0

μPC8151TB

V_{CC} = V_{out} = 3.0 V, I_{CC} = 4.2 mA

FREQUENCY MHz	S ₁₁		S ₂₁		S ₁₂		S ₂₂	
	MAG	ANG	MAG	ANG	MAG	ANG	MAG	ANG
100.0000	.843	-16.0	1.202	-178.9	.000	69.5	.996	-3.3
200.0000	.752	-27.1	1.197	-177.5	.003	120.2	1.009	-6.9
300.0000	.666	-32.4	1.221	-175.4	.003	103.2	.998	-9.9
400.0000	.603	-36.8	1.299	-174.5	.004	92.8	.986	-13.8
500.0000	.555	-40.5	1.398	-174.0	.005	88.8	.968	-17.3
600.0000	.528	-44.8	1.513	-174.9	.005	95.2	.968	-20.4
700.0000	.517	-49.9	1.691	-176.2	.007	67.5	.971	-23.1
800.0000	.525	-54.4	1.815	-178.2	.007	72.4	.972	-25.8
900.0000	.545	-58.9	2.008	179.5	.006	84.5	.960	-29.3
1000.0000	.571	-62.8	2.189	175.7	.009	78.3	.936	-32.8
1100.0000	.580	-67.3	2.399	171.2	.007	60.0	.926	-36.3
1200.0000	.588	-71.3	2.560	165.9	.007	89.5	.933	-39.5
1300.0000	.571	-76.4	2.736	157.5	.008	67.2	.941	-42.0
1400.0000	.563	-82.3	2.865	151.3	.008	79.6	.930	-45.0
1500.0000	.553	-88.8	2.946	143.3	.006	79.9	.906	-48.1
1600.0000	.552	-95.2	3.077	137.0	.006	91.4	.895	-51.5
1700.0000	.551	-101.5	3.083	130.1	.009	102.3	.888	-54.8
1800.0000	.550	-107.5	3.174	123.9	.009	100.5	.884	-57.3
1900.0000	.536	-113.3	3.164	117.4	.006	109.5	.885	-60.2
2000.0000	.517	-119.8	3.193	110.7	.009	115.9	.881	-63.4
2100.0000	.495	-127.1	3.149	104.4	.010	124.2	.870	-66.6
2200.0000	.484	-135.3	3.143	97.3	.011	122.4	.867	-69.8
2300.0000	.484	-142.6	3.135	90.5	.012	131.7	.866	-72.3
2400.0000	.490	-148.5	3.120	83.5	.015	138.1	.868	-75.5
2500.0000	.499	-152.5	3.053	78.4	.016	136.3	.866	-78.7
2600.0000	.499	-155.8	2.991	71.4	.018	142.9	.864	-82.5
2700.0000	.485	-157.4	2.958	68.0	.018	143.9	.858	-86.6
2800.0000	.464	-160.6	2.810	62.9	.021	142.5	.852	-89.7
2900.0000	.439	-164.1	2.866	57.5	.022	149.3	.872	-93.4
3000.0000	.416	-168.6	2.713	54.5	.025	148.4	.864	-96.6
3100.0000	.403	-173.6	2.635	48.0	.030	143.6	.867	-101.0

μ PC8152TB

$V_{CC} = V_{out} = 3.0\text{ V}$, $I_{CC} = 5.6\text{ mA}$

FREQUENCY MHz	S ₁₁		S ₂₁		S ₁₂		S ₂₂	
	MAG	ANG	MAG	ANG	MAG	ANG	MAG	ANG
100.0000	.062	168.0	6.691	-0.3	.002	40.8	.775	-3.3
200.0000	.047	169.1	7.049	-3.7	.001	101.6	.773	-6.6
300.0000	.055	166.9	7.418	-9.3	.003	97.3	.761	-9.1
400.0000	.078	162.1	7.883	-16.0	.003	70.7	.759	-12.0
500.0000	.101	155.6	8.311	-22.1	.005	76.7	.754	-15.3
600.0000	.121	147.4	8.583	-29.7	.004	80.5	.754	-18.3
700.0000	.135	141.2	9.093	-37.3	.006	79.8	.756	-21.3
800.0000	.143	133.2	9.276	-45.4	.005	85.9	.755	-24.7
900.0000	.146	122.4	9.572	-53.6	.009	89.6	.752	-28.1
1000.0000	.146	108.9	9.763	-62.6	.009	70.3	.745	-32.0
1100.0000	.153	97.4	9.851	-71.9	.007	90.8	.733	-36.3
1200.0000	.157	82.7	9.926	-80.5	.011	84.9	.723	-40.3
1300.0000	.164	73.3	9.816	-91.2	.010	81.9	.710	-44.3
1400.0000	.168	63.4	9.586	-99.6	.011	81.4	.679	-48.5
1500.0000	.171	56.1	9.332	-109.4	.011	82.3	.649	-52.0
1600.0000	.165	47.2	9.128	-117.9	.009	79.0	.624	-56.3
1700.0000	.164	38.7	8.544	-126.1	.011	77.5	.591	-59.2
1800.0000	.156	30.2	8.152	-133.5	.011	76.8	.557	-61.4
1900.0000	.158	25.1	7.607	-140.6	.011	75.9	.527	-63.4
2000.0000	.148	21.5	7.264	-147.5	.012	75.8	.498	-65.6
2100.0000	.140	19.1	6.759	-153.7	.013	82.6	.476	-66.8
2200.0000	.124	21.6	6.366	-159.7	.012	92.4	.455	-67.1
2300.0000	.104	19.3	6.028	-165.7	.014	88.9	.438	-68.1
2400.0000	.085	17.8	5.642	-171.5	.015	89.8	.418	-68.1
2500.0000	.068	10.9	5.200	-176.0	.015	87.2	.399	-69.5
2600.0000	.059	9.9	4.874	179.1	.016	94.2	.390	-69.2
2700.0000	.055	-0.1	4.527	175.9	.017	93.5	.380	-70.2
2800.0000	.054	0.2	4.202	171.3	.022	88.2	.372	-70.3
2900.0000	.054	1.9	4.005	167.7	.021	91.4	.369	-69.5
3000.0000	.055	12.0	3.697	164.4	.021	86.8	.360	-69.6
3100.0000	.057	22.3	3.502	160.4	.023	83.9	.352	-71.0

[MEMO]

[MEMO]

Facsimile Message

Although NEC has taken all possible steps to ensure that the documentation supplied to our customers is complete, bug free and up-to-date, we readily accept that errors may occur. Despite all the care and precautions we've taken, you may encounter problems in the documentation. Please complete this form whenever you'd like to report errors or suggest improvements to us.

From:

Name

Company

Tel.

FAX

Address

Thank you for your kind support.

North America

NEC Electronics Inc.
Corporate Communications Dept.
Fax: 1-800-729-9288
1-408-588-6130

Hong Kong, Philippines, Oceania

NEC Electronics Hong Kong Ltd.
Fax: +852-2886-9022/9044

Asian Nations except Philippines

NEC Electronics Singapore Pte. Ltd.
Fax: +65-250-3583

Europe

NEC Electronics (Europe) GmbH
Technical Documentation Dept.
Fax: +49-211-6503-274

Korea

NEC Electronics Hong Kong Ltd.
Seoul Branch
Fax: 02-528-4411

Japan

NEC Semiconductor Technical Hotline
Fax: 044-548-7900

South America

NEC do Brasil S.A.
Fax: +55-11-6465-6829

Taiwan

NEC Electronics Taiwan Ltd.
Fax: 02-2719-5951

I would like to report the following error/make the following suggestion:

Document title: _____

Document number: _____ Page number: _____

If possible, please fax the referenced page or drawing.

Document Rating	Excellent	Good	Acceptable	Poor
Clarity	<input type="checkbox"/>	<input type="checkbox"/>	<input type="checkbox"/>	<input type="checkbox"/>
Technical Accuracy	<input type="checkbox"/>	<input type="checkbox"/>	<input type="checkbox"/>	<input type="checkbox"/>
Organization	<input type="checkbox"/>	<input type="checkbox"/>	<input type="checkbox"/>	<input type="checkbox"/>