

Application Note

USAGE AND APPLICATIONS OF 6-PIN MINI-MOLD, 6-PIN SUPER MINI-MOLD SILICON HIGH-FREQUENCY WIDEBAND AMPLIFIER MMIC

μ PC2711-15

μ PC2745-49

μ PC2791/92

μ PC3210

[MEMO]

The information in this document is subject to change without notice.

The application circuits and their parameters are for reference only and are not intended for use in actual design-ins.

NESAT (NEC Silicon Advanced Technology) is a trademark of NEC Corporation.

This application note introduces general types of applications for these products. The application circuits and circuit constants described herein are only examples and are not intended for mass-production design. You should also understand that the application circuit limitations and application circuit characteristics herein are not intended to be used as product ratings nor specifications.

The characteristics of high-frequency ICs differ depending on your external components. Accordingly, you should determine external factors to suit your planned system requirements while referring this note, then confirm the characteristics before using these products.

No part of this document may be copied or reproduced in any form or by any means without the prior written consent of NEC Corporation. NEC Corporation assumes no responsibility for any errors which may appear in this document.

NEC Corporation does not assume any liability for infringement of patents, copyrights or other intellectual property rights of third parties by or arising from use of a device described herein or any other liability arising from use of such device. No license, either express, implied or otherwise, is granted under any patents, copyrights or other intellectual property rights of NEC Corporation or of others.

[MEMO]

CONTENTS

1. INTRODUCTION	7
2. PRODUCT LINEUP	7
2.1 Characteristics	7
2.2 Manufacturing Process.....	9
2.3 Application Examples	9
3. THEORETICAL DESCRIPTION.....	10
3.1 Description of Internal Circuits.....	10
3.2 Description of External Circuits.....	12
3.3 Description of Test Circuit	13
4. EXTERNAL CIRCUIT COMPONENTS AND APPLICATION CHARACTERISTICS.....	16
5. EXAMPLE OF ADJUSTING CHARACTERISTICS VIA PERIPHERAL CIRCUITS	18
5.1 Example of Adjusting Mismatched Voltage in the Systems.....	18
5.2 Example of Adjustment between Stages	19
6. SUMMARY	20
REFERENCES.....	20
APPENDIX TYPICAL S-PARAMETER VALUES	21

CAUTIONS

- (1) Observe precautions for handling because of electro-static sensitive devices.
- (2) Form a ground pattern as widely as possible to minimize ground impedance (to prevent undesired oscillation).
All the ground pins must be connected together with wide ground pattern to decrease impedance difference.
- (3) The bypass capacitor should be attached to V_{CC} line.
- (4) The DC cut capacitor must be each attached to input and output pin. (Determine the capacitance value based on the used frequency).
- (5) Voltage should only be applied at the V_{CC} pin. Voltage must not be applied via an input/output pin, nor should the pin voltage be externally regulated such as via direct pull-down.
- (6) The IC's internal circuit feedback cannot be modified externally.

[MEMO]

1. INTRODUCTION

The application for high-frequency devices has grown to include not only TV/VCR tuners and cable TV converters but also, more recently, DBS, cellular phones, pagers, and GPS. In response to these increasingly diverse needs, NEC has developed an abundant lineup of high-frequency amplifier ICs.

This application note is intended to describe the selection for design purposes or the application as an external circuit reference for certain characteristics in the 6-pin mini mold and super mini mold products, among NEC's lineup of silicon high-frequency wideband amplifier ICs.

Refer to the product data sheet for details of the product's ratings, specifications, and test conditions.

2. PRODUCT LINEUP

2.1 Characteristics

While a wide assortment of silicon high-frequency wideband amplifier ICs are listed in product references such as NEC's Selection Guide, this application note focuses on μ PC2711 to 2715, μ PC2745 to 2749, μ PC2791/92, and μ PC3210, packaged in a 6-pin mini mold or super mini mold. Table 2-1 lists these products and their characteristics. These products cover three power supply voltage ranges, the 5-V range, 3.4-V range, and 3-V range, and include various frequencies, output levels, and power gains. These products are available in two package sizes: size 2915 (6-pin mini mold) and size 2012 (6-pin super mini mold). The dimensions of these packages are shown in Figure 2-1.

Three characters are marked instead of the part number shown on the molds, due to limited printing space on these small molds. Each marking corresponds to a different product name. Due to space limitations, the pin 1 mark is printed on the bottom side. Figure 2-2 illustrates an example of markings. The "T" or "TB" that appears after the part number is a package code: "TB" indicates super mini mold and "T" indicates mini mold.

When two package codes appear on the same product, such as on a μ PC2711, they indicate that the same specifications apply to two package types in the product lineup. The marking is the same on both package types, but the products can be distinguished by their package sizes.

All the products are available in taping form and the order code is "part name plus taping code (E3)".

Table 2-1. List of Characteristics in 6-pin Mini Mold and Super Mini Mold High-Frequency Wideband Amplifier ICs ($T_A = +25^\circ\text{C}$, $Z_L = Z_S = 50 \Omega$).

Part number (Bulk part name)	V _{cc} (V)	f _u (GHz)	P _{O(sat)} (dBm)	G _p (dB)	NF (dB)	I _{cc} (mA)	Package	Marking
$\mu\text{PC2711T}$	4.5 to 5.5	DC to 2.9	+1.0	13	5.0	12	6-pin mini mold	C1G
$\mu\text{PC2711TB}$							6-pin super mini mold	
$\mu\text{PC2712T}$	4.5 to 5.5	DC to 2.6	+3.0	20	4.5	12	6-pin mini mold	C1H
$\mu\text{PC2712TB}$							6-pin super mini mold	
$\mu\text{PC2713T}$	4.5 to 5.5	DC to 1.2	+7.0	29	3.2	12	6-pin mini mold	C1J
$\mu\text{PC2714T}$	3.06 to 3.74	DC to 1.8	-7.0	11.5	5.0	4.5	6-pin mini mold	C1K
$\mu\text{PC2715T}$	3.06 to 3.74	DC to 1.2	-6.0	19	4.5	4.5	6-pin mini mold	C1L
$\mu\text{PC2745T}$	2.7 to 3.3	DC to 2.7	-1.0	12	6.0	7.5	6-pin mini mold	C1Q
$\mu\text{PC2745TB}$							6-pin super mini mold	
$\mu\text{PC2746T}$	2.7 to 3.3	DC to 1.5	0	19	4.0	7.5	6-pin mini mold	C1R
$\mu\text{PC2746TB}$							6-pin super mini mold	
$\mu\text{PC2747T}$	2.7 to 3.3	DC to 1.8	-7.0	12	3.3	5.0	6-pin mini mold	C1S
$\mu\text{PC2747TB}$							6-pin super mini mold	
$\mu\text{PC2748T}$	2.7 to 3.3	0.2 to 1.5	-3.5	19	2.8	5.0	6-pin mini mold	C1T
$\mu\text{PC2748TB}$							6-pin super mini mold	
$\mu\text{PC2749T}$	2.7 to 3.3	0.1 to 2.9	-6.0	16	4.0	6.0	6-pin mini mold	C1U
$\mu\text{PC2749TB}$							6-pin super mini mold	
$\mu\text{PC2791TB}$	4.5 to 5.5	DC to 1.9	+4.0	12	5.5	17	6-pin super mini mold	C2S
$\mu\text{PC2792TB}$	4.5 to 5.5	DC to 1.2	+5.0	22	3.5	19	6-pin super mini mold	C2T
$\mu\text{PC3210TB}$	4.5 to 5.5	DC to 2.3	+3.5	20	3.4	15	6-pin super mini mold	C2X

The above values are typical values for major characteristics. See each product's data sheet for detailed ratings, characteristic curves, etc.

Figure 2-1. Package Drawings of 6-pin Mini Mold and Super Mini Mold

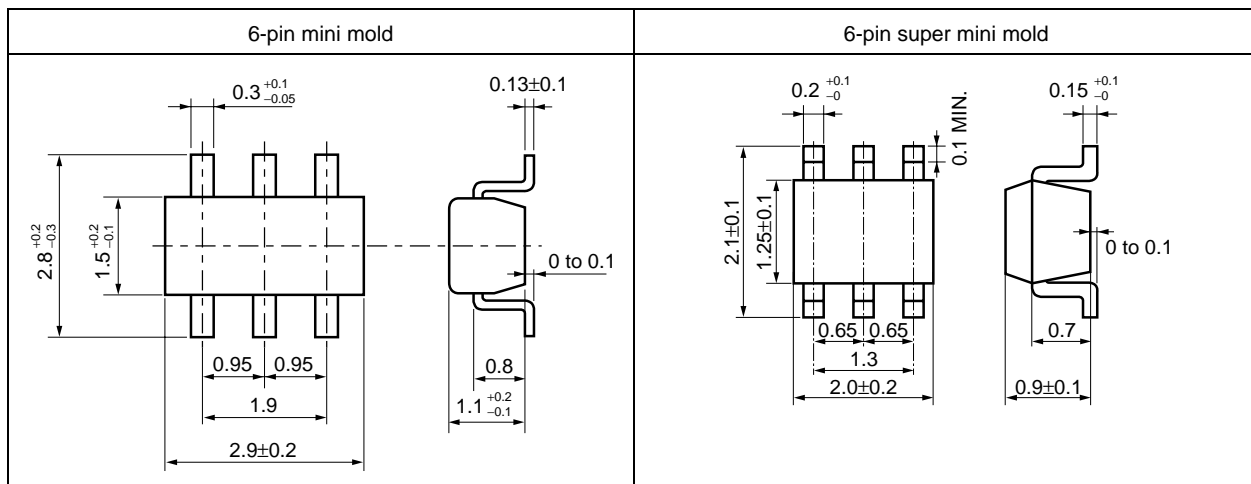
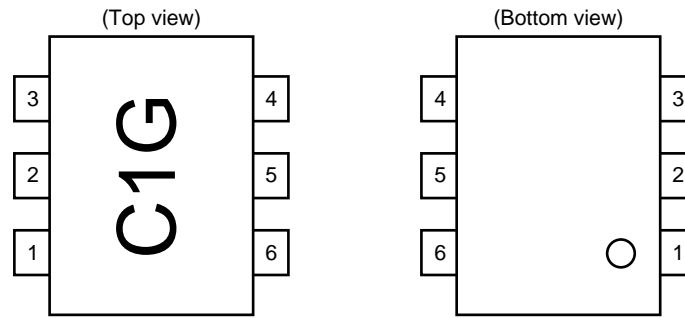

Figure 2-2. Exterior of the Marking Example



Remark The marking example shown in the figure corresponds to μ PC2711T/TB.

2.2 Manufacturing Process

The following NEC proprietary NESAT™ silicon bipolar processes are employed as the manufacturing process. NESAT III is used for the μ PC2711 to 2749 and μ PC3210, NESAT II AL is used for the μ PC2791/92. For details of the processes, refer to **NESAT Process Pamphlet (P12647E)**.

2.3 Application Examples

Table 2-2 lists several application examples. Among the lineup of products, the most suitable product can be selected based on characteristics such as maximum frequency and power supply voltage.

Table 2-2. Application Examples of High-frequency Wideband Amplifier ICs

Application	Product
1st IF stage devices such as for BS converters and BS tuners	μ PC2712T/TB
2nd local buffers for BS tuner, etc.	μ PC2711T/TB
2nd IF stage buffer for BS tuner, etc.	μ PC2713T, μ PC2791TB, μ PC2792TB
Local buffer for cellular phone, etc.	μ PC2745T/TB, μ PC2746T/TB
Wireless LAN (2.5 GHz), etc.	μ PC2745T/TB, μ PC2749T/TB
GPS receiver, etc.	μ PC2749T/TB (3 V), μ PC3210TB (5 V)

3. THEORETICAL DESCRIPTION

3.1 Description of Internal Circuits

Products in this series incorporate 50-Ω matching circuits based on the resistance at the IC's input and output stages. A two-stage configuration is employed to obtain the desired RF characteristics. This enables the IC with 50-Ω connections in a wide operating frequency range. The details of the internal circuit configurations differ according to each circuit's characteristics. An internal equivalent circuit is shown in Figure 3-1.

The respective internal circuits are described below in the order of their development.

Internal circuits of products in the μ PC2711 to 2713 Series feature a wide band with peaking capacitance inserted at the emitter side of each stage, and multiple negative feedback circuits to suppress performance deviation in the high frequency region. A Darlington-type output stage greatly increases the feedback loop gain. See the **Application Note General-Purpose High-Frequency Wideband Amplifiers μ PC1675G, μ PC1676G, μ PC1688G (P10964E)**.

By contrast, the μ PC2714's output stage transistor is not a Darlington type but is instead a single-unit type for low power consumption. The μ PC2715 has peaking capacitance at the input stage only and carries gain in the VHF band.

The μ PC2745/46 have simple two-stage configurations without negative feedback, which makes for lower voltage and can accommodate a wide band by inserting peaking capacitance at the emitter side of each stage.

The μ PC2747/48 have peaking capacitance at the output stage only and carry gain in the UHF band.

The μ PC2749 uses a Darlington-type output stage and carries gain in the L band due to its negative feedback circuit toward the base for input.

The μ PC2791/92 use multiple negative feedback and a Darlington-type output stage. The μ PC2791 has peaking capacitance inserted at the output stage emitter side to increase the bandwidth and the μ PC2792 carries gain in the VHF-band without inserting peaking capacitance.

The μ PC3210 uses a Darlington-type output stage and carries gain due to its negative feedback circuit toward the base for input, and obtains a wide band characteristic by inserting peaking capacitance at the emitter side.

The circuit GND characteristics of these devices can be improved by using several GND pins.

Note that for these products it is not possible to externally change the feedback or internal bias of the IC's internal circuitry.

Figure 3-1. Internal Equivalent Circuits of High-Frequency Wideband Amplifier ICs (1/2)

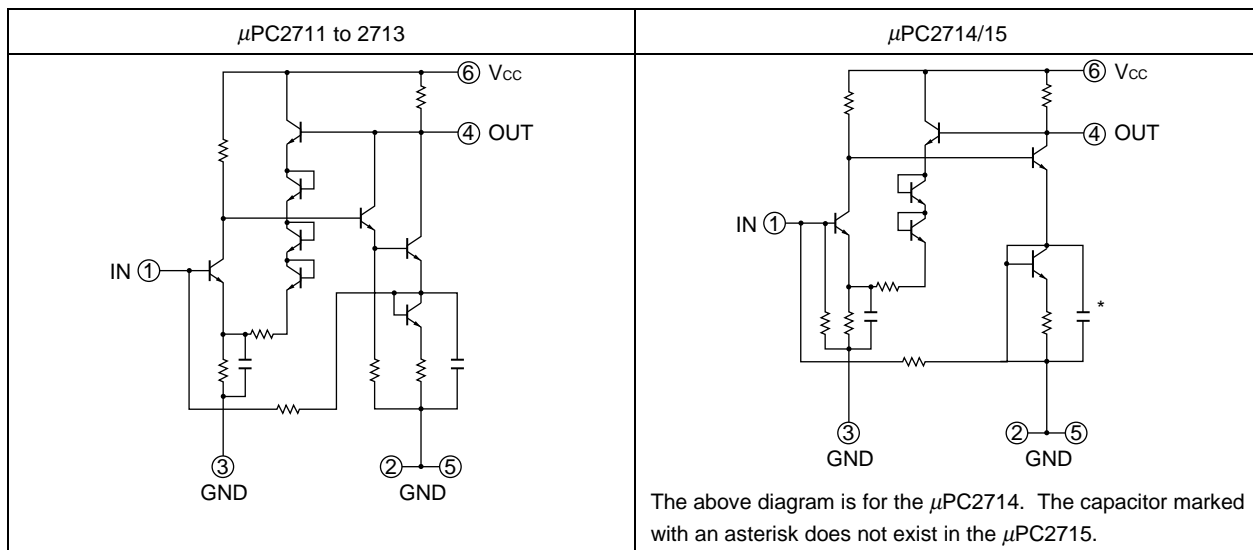
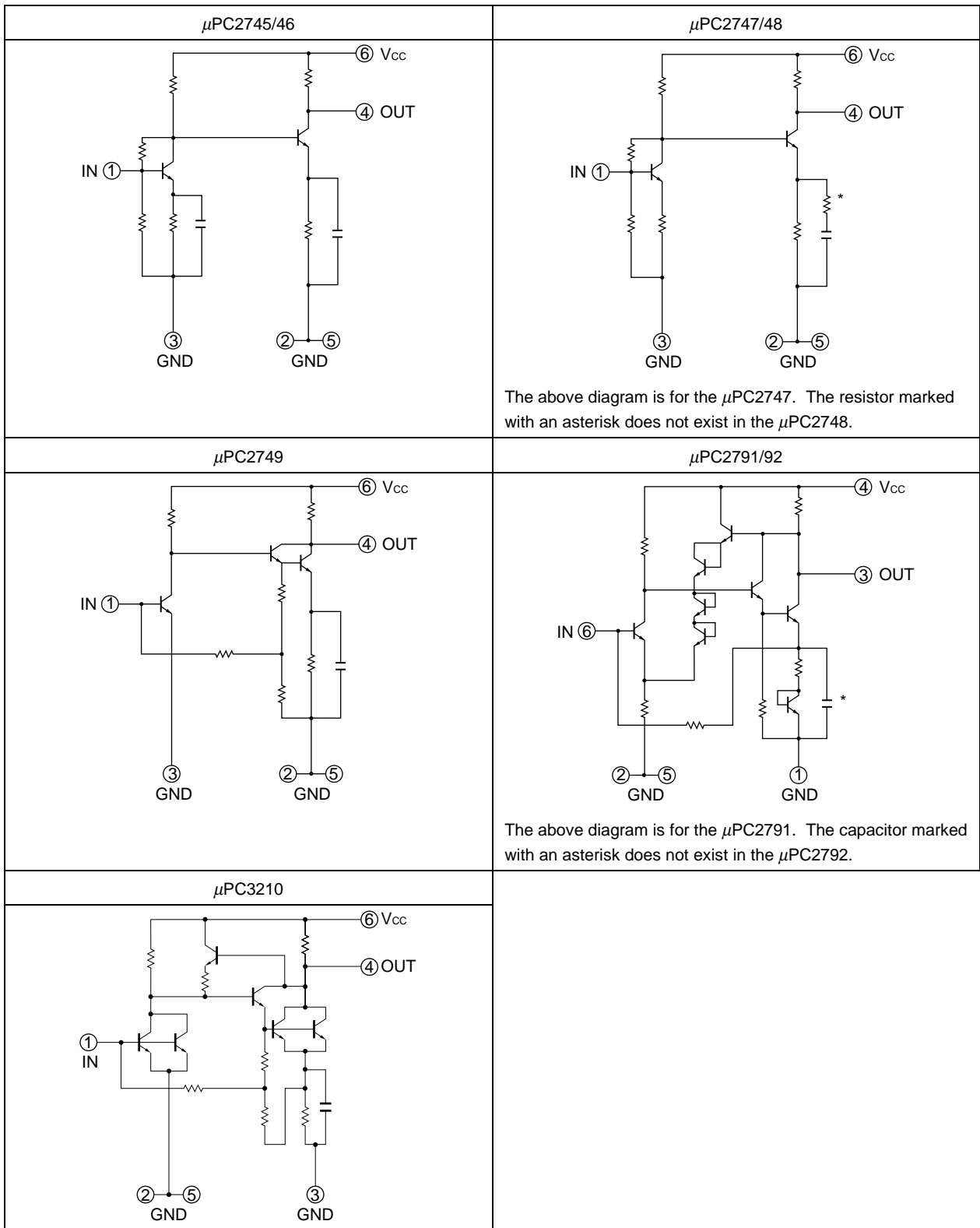

Figure 3-1. Internal Equivalent Circuits of High-Frequency Wideband Amplifier ICs (2/2)



3.2 Description of External Circuits

Since all of the devices in this product line-up have on-chip 50-Ω matching circuits and bias circuits, you should only externally attach a DC cut capacitor to input/output pins and a bypass capacitor to the V_{cc} pin to configure amplifier circuit. The bias should be applied only to the V_{cc} pin.

As is indicated by the “S₂₁” S parameter, the IC itself can operate across a wide band from DC to 3 dB down bandwidth. However, the lower frequency may be limited depending on the DC cut capacitance to the input/output pins, so the capacitance should be calculated using the following formula. The power gain shown in the data sheet’s list of electrical characteristics is value without the effect of the DC cut capacitor or indicates the S₂₁ value which its capacitance value (C) hardly affects the measured frequency.

$$C = \frac{1}{2\pi \cdot Z \cdot f_c}$$

You should check the frequency-related gain values for larger C values when using a low frequency and for smaller C values when using a high frequency. Also, externally adjusting the pin voltage such as by applying voltage to the input/output pins or by using direct pull-down is prohibited, since it causes the bias point to stray from the designed value. Any RF components should be attached to the external side of DC cut capacitor.

The power supply impedance is determined by factors such as the bypass capacitor value and insertion point. In view of the bandwidth of this IC’s, the bypass capacitor value should be 1000pF in the test circuit. In addition to the bypass capacitor value, the factors that affect the power supply impedance (to the V_{cc} pin) and the (GND pins’) ground impedance include the V_{cc} line length (which in turn is affected by the mount position) and mounting patterns such as the ground pattern. This RF grounding capacitor can decrease the frequency-band-impedance corresponding to the capacitance value, which prevents the intrusion or occurrence of power supply noise at the V_{cc} pin. As mentioned above, 1000 pF is considered a suitable bypass capacitance value for the V_{cc} line. However, you should note that V_{cc} line inductance grows and its impedance rises unless the bypassed ground pattern is widened or a through hole is used to link the pattern.

Although there are three GND pins, a ground pattern should be connected together and grounding unified so as to avoid any impedance differences among the pins that might generate oscillation.

Figure 3-3. 6-pin Mini Mold Board AMP-1 Used for Jig

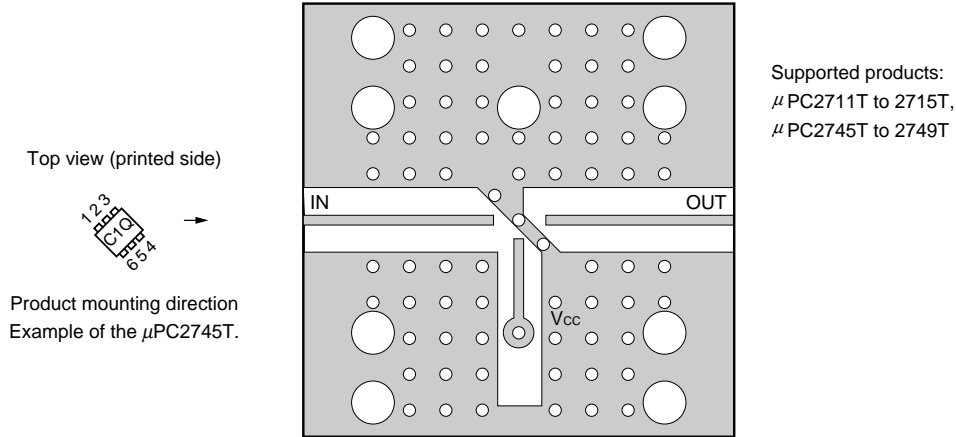

Figure 3-4. 6-pin Super Mini Mold Board AMP-2 Used for Jig

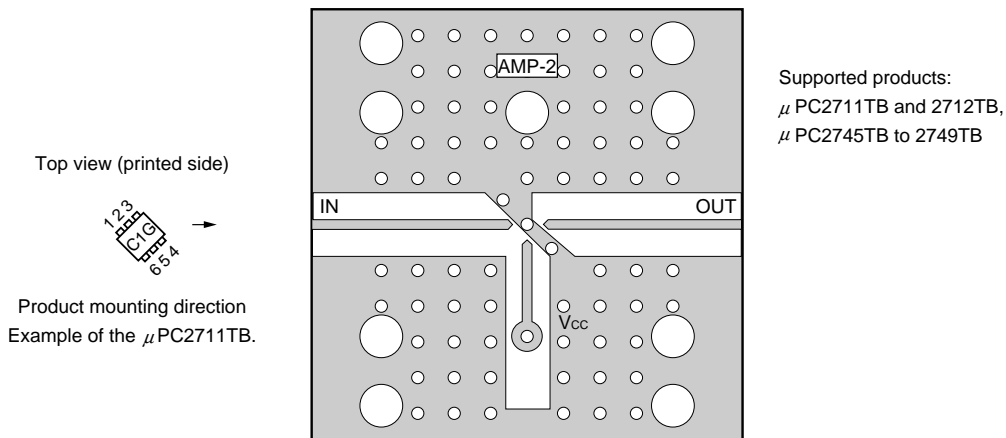
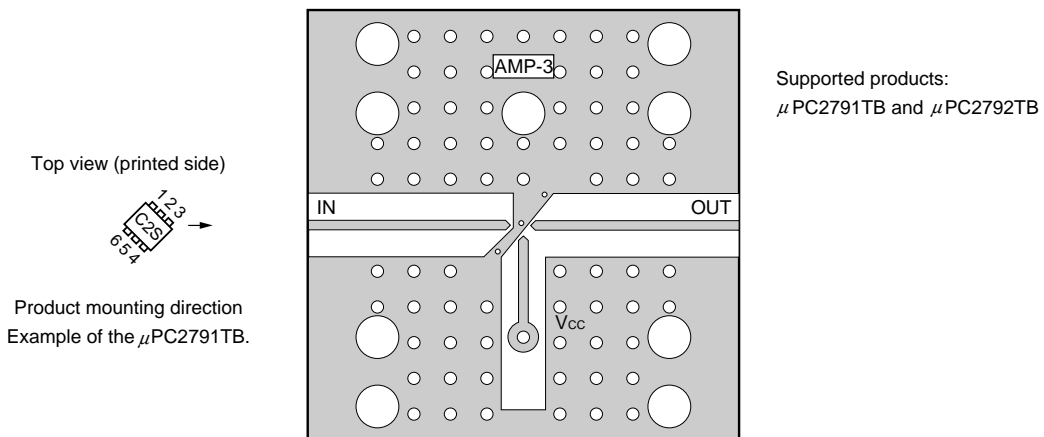

Figure 3-5. 6-pin Super Mini Mold Board AMP-3 Used for Jig



Notes regarding board examples

- (*1) 35 μ m double sided copper clad 30 × 30 × 0.4 mm polyimide PCB
- (*2) Solder on patterning surfaces
- (*3) Circles indicate through holes
- (*4) Back side ground pattern

Figure 3-6. Board Used for μ PC3210TB Jig

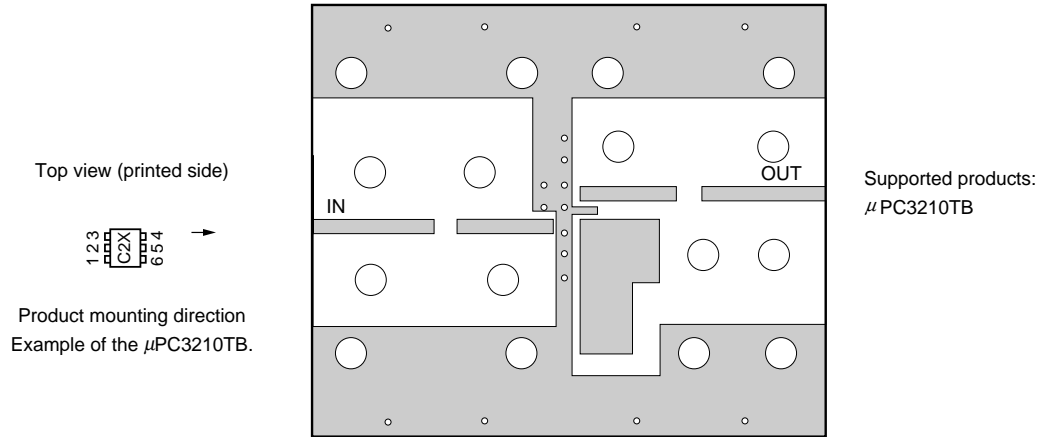

Notes regarding board examples

- (*1) 18 μ m double sided copper clad 42 × 35 × 0.4 mm polyimide PCB
- (*2) Solder on patterning surfaces
- (*3) Circles indicate through holes
- (*4) Back side ground pattern

4. EXTERNAL CIRCUIT COMPONENTS AND APPLICATION CHARACTERISTICS

For a reference, Figure 4-1 illustrates how power gain is viewed based on the output side's DC cut capacitance value. As shown in the data sheet, the IC's operation is a wideband operation and the DC cut capacitor does not limit the IC's operation but instead limits the pass band. Accordingly, as a typical example, the following shows how the high-pass characteristics of the μ PC2749T's DC cut capacitor affects the view of the IC's bandwidth.

The power gain can be confirmed as being at least 200 MHz when DC cut capacitance value is 10 pF, or at least 100 MHz when the DC cut capacitance value is 200 pF (above 100 MHz, there was no power gain difference between 1000 pF and 200 pF capacitance). For example, as shown by "2 pF" in the figure, power gain is reduced completely when the capacitance is small. Consequently, the DC cut capacitor with a value of at least 10 pF should be selected according to the bandwidth to be used.

Figure 4-1. Power Gain based on Output Side DC Cut Capacitance Value (Example Using μ PC2749T)

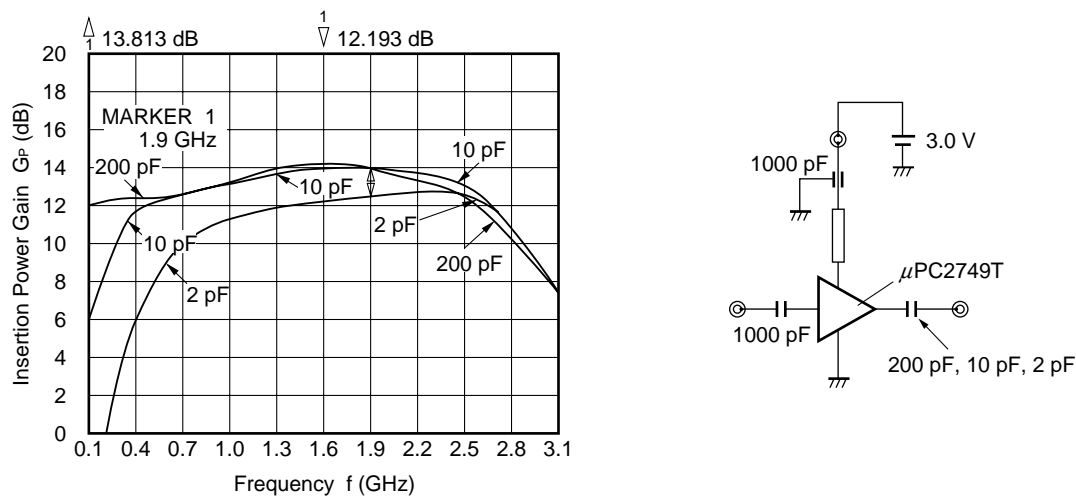

Figure 4-2 illustrates the change in power gain that occurs when a bypass capacitor insertion position for the V_{CC} line is changed.

Figure 4-2 examines V_{CC} pin load characteristics dependent on internal circuit. For typical circuit models, μ PC2712T, μ PC2745T, and μ PC2749T, were selected. In each graph, curve <1> is a result of only the evaluation PCB's feed-through capacitor (1000 pF), curve <2> is a result of an additional 1000-pF chip capacitor mounted on the PCB near feed-through capacitor insertion point, and curve <3> is a result of the 1000-pF chip capacitor moved close to the IC's mount position. These measurements are compared to the internal circuit. In other words, for curve <1>, the load from the feed through capacitor's leads + the V_{CC} pattern (about 7 nH) is connected to the IC's V_{CC} pin. For curve <2>, the load from only the V_{CC} pattern (about 5 nH) is connected to the IC's V_{CC} pin.

In the μ PC2712T, μ PC2745T, and μ PC2747T, the power gain changes less than 1 dB while in the μ PC2749T changes close to 2 dB. This is because, in the μ PC2712T and PC2745T circuit which have a resistance or capacitance inserted to the internal input stage transistor's emitter side or a multiple negative feedback circuit, the power gain is determined by the ratio of the emitter-side resistance to the collector-side resistance, so power gain hardly changes affected by the higher V_{CC} pin load impedance. However, in the μ PC2749T, because the internal input stage transistor's emitter is directly grounded, the transistor's emitter resistance is itself small, which makes it easily affected by the V_{CC} pin load impedance which is added to the collector-side resistance. In comparison with the μ PC2747T, which is considered to have a similar tendency, the μ PC2749T has a Darlington output stage, so the output-stage gain might further amplify the effect of the V_{CC} pin's load impedance.

Therefore, to increase the power gain when actually using the μ PC2749T, insert a choke coil (or similar component) into the V_{CC} pin pad and check the characteristics to determine the choke coil's inductance value.

Figure 4-2. Power Gain and Bypass Capacitor Insertion Position for Vcc Line

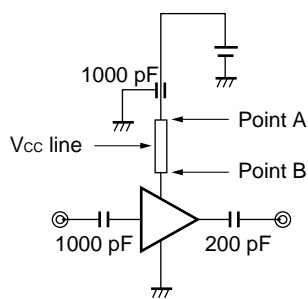
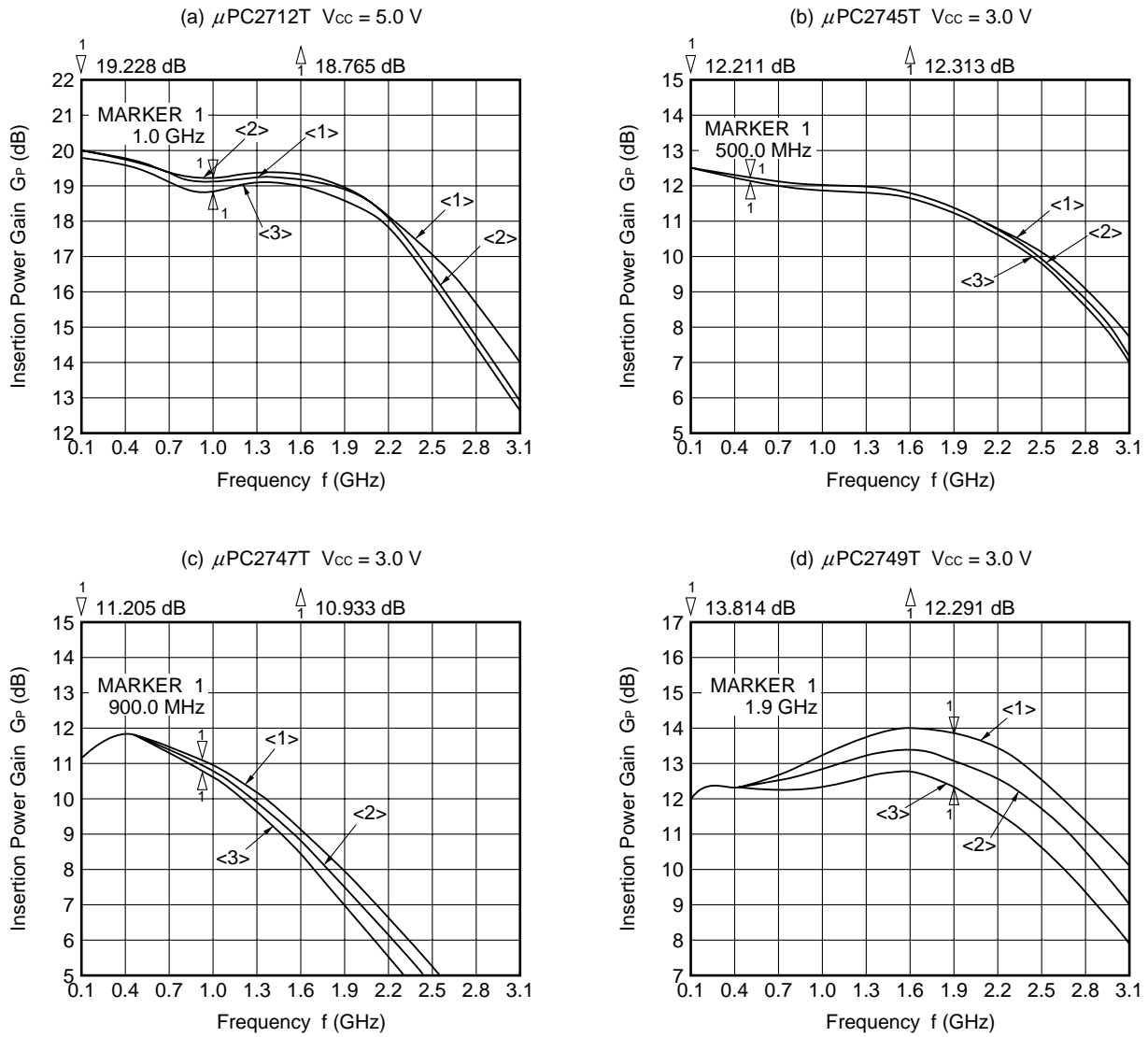

Top view (printed side)

Product mounting direction
(Example of the
 μ PC2745T)

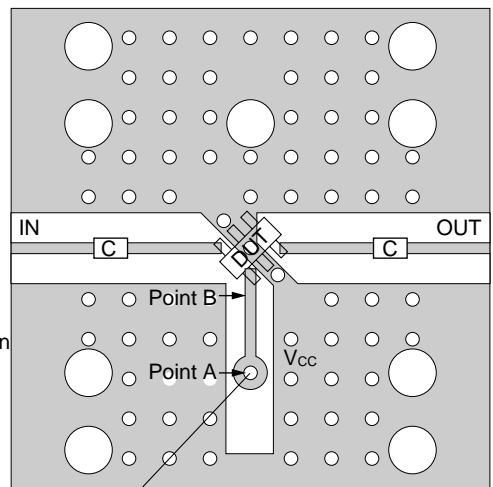

Center hole is feed through capacitor insertion point.

Relation between graph and bypass capacitor point for Vcc line

- <1> Only feed through capacitor for jigs
- <2> Additional chip capacitor (1000-pF) at point A
- <3> Chip capacitor (1000-pF) is moved to point B from point A

5. EXAMPLE OF ADJUSTING CHARACTERISTICS VIA PERIPHERAL CIRCUITS

This section describes an example of a general high-frequency circuit technology that involves peripheral circuits and is not an application specific to this product line-up. For further information on this technology, you should refer to the literature on high-frequency circuits available in book stores and so on.

5.1 Example of Adjusting Mismatched Voltage in the Systems

The power supply voltage rating includes a guaranteed operation range margin of TYP $\pm 10\%$. This lineup includes products with power supply voltage ranges of 2.7 to 3.3 V, 3.06 to 3.74 V, and 4.5 to 5.5 V. Therefore, when using one of these products in a system whose power supply voltage range is 3.8 to 4.4 V, you can use a resistance type potential divider or a similar circuit to adjust the voltage applied to the IC within the rated range.

Figure 5-1. Example of Adjusting Applied Voltage to IC in Mismatched Voltage Systems

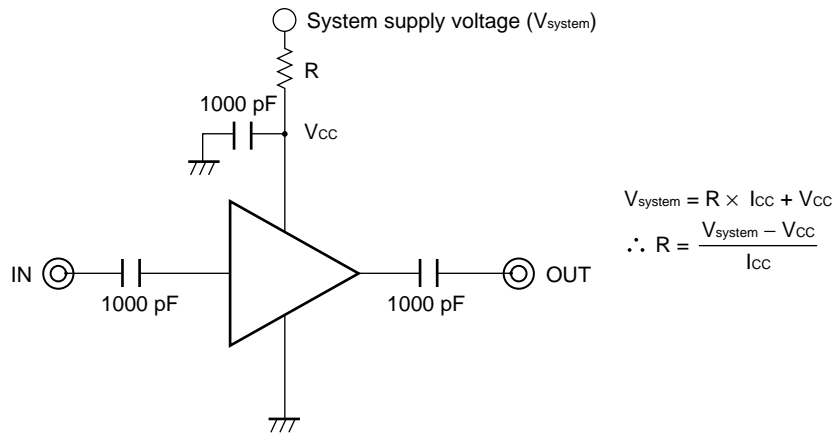

5.2 Example of Adjustment between Stages

When using multi-stage connections, you can insert terminating resistors between stages or insert a π -type 3-dB pad to suppress load variation and to suppress gain as preventing oscillation.

The use of passive components such as resistors is an effective design method for suppressing load variation caused by the IC's ON/OFF switching and gain variation that tends to occur in multi-stage connections. Some very general examples are shown in Figure 5-2 below.

You should consider the signal-level diagrams in order not to make the second-stage IC's input level a super-saturated region.

Figure 5-2. Example of Adjustment between Stages

Example of using terminating resistor to prevent load variation

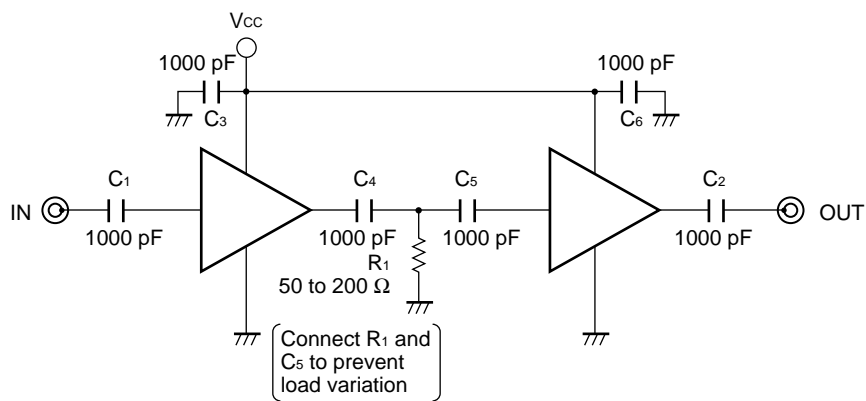

Example of inserting π -type 3-dB pad to prevent gain load variation

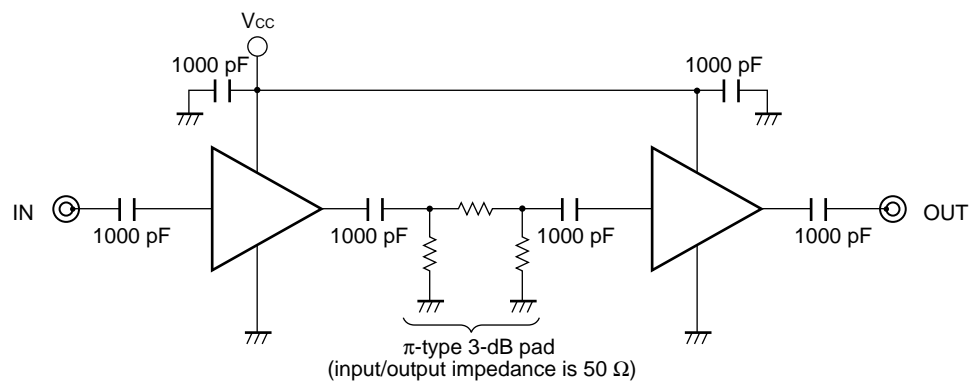

6. SUMMARY

As has been explained above, these products can be selected based on their internal circuit configurations and their high-frequency characteristics, and can be applied in designs that achieve stable characteristics with a minimum of external components.

REFERENCES

- Application Note General-Purpose High-Frequency Wideband Amplifiers μ PC1675G, μ PC1676G, μ PC1688G (P10964E)
- μ PC2711T Data Sheet (P12428E)
- μ PC2712T Data Sheet (P12429E)
- μ PC2711TB, μ PC2712TB Data Sheet (P11510E)
- μ PC2713T Data Sheet (P12430E)
- μ PC2714T Data Sheet (P12431E)
- μ PC2715T Data Sheet (P12432E)
- μ PC2745T, μ PC2749T Data Sheet (IC-3590)
- μ PC2745TB, μ PC2746TB Data Sheet (P11511E)
- μ PC2746T, μ PC2747T, μ PC2748T Data Sheet (P10893E)
- μ PC2747TB, μ PC2748TB Data Sheet (P13444E)
- μ PC2749TB Data Sheet (P13489E)
- μ PC2791TB, μ PC2792TB Data Sheet (P11863E)
- μ PC3210TB Data Sheet (P13593E)
- Other reference sources: literature on Design and Fabrication of High-frequency Circuits (For example, Published by CQ Publishing in Japan).

The data sheets listed above may include preliminary versions. However, preliminary versions are not marked as such.

APPENDIX TYPICAL S-PARAMETER VALUES (T_A = +25°C)

μPC2711T

V_{CC} = 5.0 V, I_{CC} = 12 mA

FREQUENCY MHz	S ₁₁		S ₂₁		S ₁₂		S ₂₂		K	S ₂₁ dB
	MAG	ANG	MAG	ANG	MAG	ANG	MAG	ANG		
100.0000	0.115	-13.9	4.1	-5.3	0.036	-1.3	0.098	-2.1	3.34	12.3
200.0000	0.110	-22.1	4.1	-12.1	0.035	-2.0	0.103	2.7	3.44	12.3
300.0000	0.104	-31.2	4.1	-18.3	0.034	-4.8	0.106	4.8	3.54	12.3
400.0000	0.096	-41.7	4.2	-24.0	0.033	-5.1	0.116	5.6	3.63	12.4
500.0000	0.085	-52.0	4.2	-29.9	0.032	-7.5	0.126	6.6	3.70	12.4
600.0000	0.080	-58.8	4.2	-35.6	0.031	-8.9	0.142	4.1	3.82	12.4
700.0000	0.071	-74.8	4.2	-41.3	0.030	-10.6	0.150	2.2	3.87	12.6
800.0000	0.056	-88.7	4.3	-47.6	0.029	-10.7	0.160	0.5	3.94	12.7
900.0000	0.044	-103.9	4.3	-54.2	0.028	-11.4	0.173	-2.6	4.03	12.8
1000.0000	0.030	-125.2	4.4	-61.0	0.027	-13.2	0.187	-5.3	4.13	12.8
1200.0000	0.028	149.4	4.5	-74.4	0.024	-11.0	0.211	-13.4	4.47	13.1
1400.0000	0.060	96.8	4.6	-89.4	0.022	-9.9	0.233	-21.3	4.75	13.2
1600.0000	0.103	72.8	4.6	-104.8	0.020	-5.6	0.250	-30.2	5.11	13.2
1800.0000	0.150	53.6	4.5	-121.3	0.019	7.0	0.259	-38.4	5.38	13.1
2000.0000	0.201	38.3	4.5	-136.9	0.020	20.8	0.264	-46.0	5.08	13.0
2200.0000	0.244	26.8	4.3	-152.6	0.021	28.7	0.261	-53.5	4.94	12.6
2400.0000	0.284	17.2	4.1	-167.4	0.026	29.9	0.244	-59.5	4.16	12.2
2600.0000	0.318	8.4	3.8	178.2	0.031	33.7	0.222	-62.9	3.70	11.6
2800.0000	0.347	1.8	3.5	165.2	0.034	31.7	0.198	-62.8	3.58	11.0
3000.0000	0.369	-3.9	3.3	152.4	0.039	29.9	0.175	-58.8	3.35	10.4
3200.0000	0.386	-8.4	3.1	140.5	0.043	27.3	0.163	-49.0	3.25	9.7
3400.0000	0.397	-11.9	2.8	129.0	0.048	24.7	0.162	-37.3	3.14	9.1

μPC2712T

V_{CC} = 5.0 V, I_{CC} = 12 mA

FREQUENCY MHz	S ₁₁		S ₂₁		S ₁₂		S ₂₂		K	S ₂₁ dB
	MAG	ANG	MAG	ANG	MAG	ANG	MAG	ANG		
100.0000	0.262	-9.3	9.3	-6.4	0.021	-1.6	0.071	7.8	2.46	19.3
200.0000	0.261	-12.3	9.4	-17.4	0.022	-3.3	0.078	7.2	2.33	19.5
300.0000	0.260	-17.0	9.5	-27.7	0.022	-5.1	0.091	6.4	2.29	19.6
400.0000	0.258	-21.9	9.6	-37.5	0.023	-6.8	0.110	4.3	2.16	19.7
500.0000	0.257	-27.1	9.8	-46.9	0.024	-8.5	0.128	-1.1	2.05	19.8
600.0000	0.255	-32.0	9.9	-56.4	0.024	-10.2	0.146	-6.8	2.01	19.9
700.0000	0.254	-38.1	10.0	-65.7	0.025	-12.0	0.166	-14.9	1.90	20.0
800.0000	0.252	-41.9	10.2	-75.9	0.026	-13.7	0.181	-22.9	1.80	20.1
900.0000	0.250	-46.5	10.3	-86.0	0.026	-15.4	0.194	-32.7	1.77	20.3
1000.0000	0.248	-51.0	10.4	-96.4	0.027	-17.2	0.204	-40.5	1.69	20.4
1100.0000	0.246	-57.5	10.6	-106.4	0.028	-18.9	0.212	-50.9	1.62	20.5
1200.0000	0.240	-62.5	10.6	-117.7	0.028	-20.6	0.221	-59.7	1.60	20.5
1300.0000	0.236	-67.8	10.7	-128.9	0.029	-22.3	0.235	-70.9	1.54	20.6
1400.0000	0.232	-72.4	10.8	-140.6	0.030	-24.1	0.244	-81.3	1.48	20.6
1500.0000	0.224	-77.7	10.8	-152.7	0.031	-25.8	0.247	-94.4	1.44	20.7
1600.0000	0.218	-82.1	10.9	-164.9	0.031	-27.5	0.246	-106.3	1.44	20.7
1700.0000	0.210	-86.2	10.9	-177.6	0.032	-29.3	0.240	-119.4	1.42	20.7
1800.0000	0.201	-89.3	10.7	169.5	0.033	-31.0	0.234	-131.5	1.42	20.6
1900.0000	0.190	-93.5	10.5	156.4	0.033	-32.7	0.221	-143.3	1.46	20.4
2000.0000	0.180	-96.9	10.3	143.7	0.034	-34.4	0.210	-159.0	1.46	20.3
2100.0000	0.173	-98.4	10.0	129.8	0.035	-36.2	0.187	-173.4	1.48	20.0
2200.0000	0.169	-101.3	9.7	119.3	0.035	-37.9	0.169	167.5	1.54	19.7
2300.0000	0.161	-100.3	8.8	107.2	0.036	-39.6	0.156	151.8	1.63	18.9
2400.0000	0.157	-100.0	8.4	95.8	0.037	-41.3	0.134	132.8	1.69	18.4
2500.0000	0.156	-99.4	7.7	84.9	0.037	-43.1	0.125	114.0	1.80	17.8
2600.0000	0.156	-100.0	7.3	75.4	0.038	-44.8	0.118	89.8	1.85	17.3
2700.0000	0.159	-98.4	6.8	64.5	0.038	-46.5	0.108	65.4	2.00	16.6
2800.0000	0.164	-101.7	6.5	56.1	0.039	-48.3	0.110	50.2	2.02	16.2
2900.0000	0.168	-100.1	5.8	47.0	0.039	-50.0	0.122	32.2	2.21	15.3
3000.0000	0.172	-101.1	5.5	36.2	0.040	-51.7	0.136	15.6	2.28	14.8

μPC2713T

V_{CC} = 5.0 V, I_{CC} = 12 mA

FREQUENCY MHz	S ₁₁		S ₂₁		S ₁₂		S ₂₂		K	S ₂₁ dB
	MAG	ANG	MAG	ANG	MAG	ANG	MAG	ANG		
100.0000	0.350	-21.8	21.9	-8.1	0.006	25.6	0.286	-10.3	3.07	26.8
200.0000	0.290	-33.1	22.0	-25.3	0.006	24.9	0.298	-16.1	3.17	26.9
300.0000	0.243	-41.7	22.1	-37.3	0.007	23.7	0.313	-25.6	2.77	26.9
400.0000	0.207	-47.3	22.3	-48.6	0.007	22.4	0.327	-35.2	2.78	27.0
500.0000	0.185	-50.5	22.4	-60.0	0.007	21.6	0.336	-45.4	2.78	27.0
600.0000	0.176	-54.0	22.6	-72.7	0.008	20.1	0.348	-56.9	2.41	27.1
700.0000	0.161	-57.5	22.8	-85.7	0.008	19.0	0.359	-69.0	2.39	27.1
800.0000	0.148	-60.2	22.9	-100.7	0.009	18.3	0.366	-82.9	2.13	27.2
900.0000	0.127	-63.9	22.8	-114.8	0.009	17.2	0.366	-96.8	2.15	27.2
1000.0000	0.111	-62.9	22.3	-132.0	0.009	16.4	0.359	-111.8	2.23	27.0
1100.0000	0.097	-56.5	21.6	-147.6	0.010	15.7	0.343	-126.8	2.12	26.7
1200.0000	0.095	-48.2	20.6	-163.1	0.010	14.4	0.320	-142.3	2.24	26.3
1300.0000	0.098	-40.1	18.9	-177.8	0.010	13.1	0.291	-156.6	2.47	25.5
1400.0000	0.110	-35.7	17.6	168.3	0.010	12.0	0.263	-171.7	2.68	24.9
1500.0000	0.129	-34.6	15.6	154.8	0.011	11.8	0.234	174.3	2.77	23.9
1600.0000	0.145	-36.2	14.2	142.7	0.012	11.2	0.208	160.8	2.81	23.0
1700.0000	0.161	-40.0	12.6	130.5	0.013	10.8	0.185	147.1	2.92	22.0
1800.0000	0.179	-44.7	11.4	120.9	0.014	9.8	0.164	132.6	3.02	21.1
1900.0000	0.191	-50.3	10.2	110.1	0.015	7.5	0.148	119.5	3.15	20.1
2000.0000	0.197	-56.1	9.3	100.8	0.016	5.5	0.137	107.4	3.23	19.4

μPC2714T

V_{CC} = 3.4 V, I_{CC} = 4.5 mA

FREQUENCY MHz	S ₁₁		S ₂₁		S ₁₂		S ₂₂		K	S ₂₁ dB
	MAG	ANG	MAG	ANG	MAG	ANG	MAG	ANG		
100.0000	0.123	-169.9	3.6	-6.4	0.069	-12.0	0.190	13.3	2.04	11.2
200.0000	0.133	167.3	3.7	-19.2	0.061	-24.5	0.266	8.7	2.17	11.3
300.0000	0.139	150.5	3.7	-30.6	0.056	-32.7	0.326	2.9	2.25	11.4
400.0000	0.151	135.1	3.8	-41.8	0.048	-42.9	0.366	-4.0	2.49	11.5
500.0000	0.165	120.6	3.8	-53.2	0.040	-48.8	0.394	-11.1	2.86	11.5
600.0000	0.176	105.6	3.7	-64.7	0.035	-53.4	0.414	-19.4	3.19	11.4
700.0000	0.187	91.5	3.7	-76.3	0.031	-52.7	0.429	-27.3	3.55	11.4
800.0000	0.197	77.8	3.7	-87.9	0.025	-51.7	0.436	-35.3	4.36	11.3
900.0000	0.205	64.6	3.6	-99.5	0.024	-47.1	0.439	-43.2	4.60	11.1
1000.0000	0.215	51.9	3.5	-111.1	0.022	-43.5	0.439	-50.6	5.08	11.0
1100.0000	0.219	39.2	3.4	-122.5	0.023	-38.2	0.432	-58.0	5.00	10.8
1200.0000	0.225	28.3	3.3	-133.8	0.024	-32.0	0.422	-64.8	4.96	10.5
1300.0000	0.228	17.3	3.2	-145.0	0.025	-31.8	0.412	-71.4	4.97	10.2
1400.0000	0.231	6.6	3.1	-156.1	0.026	-31.7	0.400	-77.8	5.01	9.8
1500.0000	0.231	-2.8	3.0	-166.8	0.028	-31.4	0.387	-83.4	4.90	9.5
1600.0000	0.232	-12.7	2.9	-177.4	0.029	-34.1	0.374	-88.9	4.97	9.1
1700.0000	0.231	-21.3	2.7	172.2	0.030	-36.7	0.359	-94.1	5.11	8.7
1800.0000	0.229	-29.4	2.6	162.0	0.032	-37.1	0.348	-98.5	5.08	8.3
1900.0000	0.226	-38.0	2.5	151.9	0.033	-40.2	0.335	-103.2	5.20	7.9
2000.0000	0.223	-44.8	2.4	142.3	0.035	-41.0	0.322	-107.4	5.21	7.5
2100.0000	0.216	-51.3	2.2	132.3	0.036	-47.1	0.311	-111.5	5.39	7.0
2200.0000	0.212	-57.8	2.1	122.8	0.037	-49.4	0.298	-115.3	5.57	6.6
2300.0000	0.208	-63.4	2.0	113.7	0.039	-52.7	0.287	-118.9	5.61	6.2
2400.0000	0.204	-68.2	1.9	104.6	0.040	-58.2	0.276	-122.2	5.81	5.7
2500.0000	0.201	-72.9	1.8	95.6	0.041	-58.7	0.270	-125.7	5.97	5.3

μPC2715T

V_{CC} = 3.4 V, I_{CC} = 4.5 mA

FREQUENCY MHz	S ₁₁		S ₂₁		S ₁₂		S ₂₂		K	S ₂₁ dB
	MAG	ANG	MAG	ANG	MAG	ANG	MAG	ANG		
100.0000	0.052	33.7	7.7	-8.4	0.031	-7.8	0.254	8.1	2.07	17.7
200.0000	0.087	21.3	7.8	-25.7	0.028	-12.6	0.279	3.6	2.20	17.8
300.0000	0.121	9.5	7.9	-40.9	0.025	-17.8	0.311	-1.0	2.35	17.9
400.0000	0.141	-2.1	7.9	-55.9	0.022	-20.3	0.351	-6.4	2.54	18.0
500.0000	0.159	-12.4	7.9	-69.5	0.020	-21.2	0.383	-13.0	2.68	18.0
600.0000	0.175	-27.8	7.7	-84.9	0.019	-19.7	0.409	-21.3	2.79	17.7
700.0000	0.181	-40.7	7.4	-98.4	0.019	-15.7	0.426	-30.2	2.82	17.4
800.0000	0.184	-52.3	7.2	-112.0	0.019	-13.3	0.432	-39.1	2.87	17.2
900.0000	0.187	-66.1	6.9	-125.6	0.020	-12.3	0.432	-48.1	2.83	16.8
1000.0000	0.187	-78.4	6.6	-138.9	0.021	-11.2	0.426	-56.3	2.85	16.4
1100.0000	0.186	-89.3	6.3	-150.8	0.022	-11.6	0.412	-64.2	2.87	16.0
1200.0000	0.182	-101.5	6.1	-162.7	0.023	-12.1	0.394	-71.2	2.93	15.6
1300.0000	0.178	-113.8	5.7	-174.5	0.024	-14.5	0.377	-77.5	3.06	15.0
1400.0000	0.173	-125.4	5.3	174.3	0.025	-16.3	0.359	-83.4	2.22	14.4
1500.0000	0.167	-137.1	4.9	163.7	0.026	-18.3	0.343	-88.3	3.35	13.9
1600.0000	0.163	-148.4	4.6	153.2	0.027	-20.6	0.328	-93.1	2.53	13.2
1700.0000	0.157	-160.0	4.2	143.1	0.028	-22.2	0.315	-97.2	3.72	12.5
1800.0000	0.152	-171.6	3.9	133.2	0.029	-23.9	0.306	-100.8	3.90	11.9
1900.0000	0.148	176.8	3.7	123.5	0.030	-25.6	0.296	-104.7	4.07	11.3
2000.0000	0.142	164.7	3.4	114.5	0.031	-27.1	0.286	-108.9	4.28	10.6

μPC2745T

V_{CC} = 3.0 V, I_{CC} = 7.5 mA

FREQUENCY MHz	S ₁₁		S ₂₁		S ₁₂		S ₂₂		K	S ₂₁ dB
	MAG	ANG	MAG	ANG	MAG	ANG	MAG	ANG		
100.0000	0.267	-2.0	4.22	-5.2	0.003	92.2	0.611	-4.1	23.00	12.5
200.0000	0.277	-5.5	4.23	-11.9	0.006	82.3	0.597	-9.2	11.71	12.5
300.0000	0.278	-9.3	4.23	-18.7	0.009	74.0	0.584	-13.5	7.97	12.5
400.0000	0.276	-13.8	4.24	-25.6	0.012	66.5	0.569	-17.1	6.12	12.5
500.0000	0.276	-17.5	4.24	-32.0	0.014	60.1	0.557	-20.4	5.33	12.5
600.0000	0.275	-20.8	4.26	-38.8	0.016	56.2	0.542	-23.4	4.75	12.6
700.0000	0.274	-24.4	4.30	-45.8	0.017	54.6	0.530	-26.1	4.51	12.7
800.0000	0.273	-26.9	4.31	-52.9	0.018	53.5	0.520	-29.1	4.31	12.7
900.0000	0.272	-29.9	4.32	-60.1	0.020	51.0	0.511	-31.8	3.92	12.7
1000.0000	0.272	-31.4	4.34	-67.5	0.021	49.8	0.504	-34.3	3.74	12.8
1200.0000	0.270	-34.3	4.38	-82.0	0.023	46.4	0.493	-40.3	3.43	12.8
1400.0000	0.266	-37.3	4.37	-97.6	0.024	42.6	0.481	-46.5	3.35	12.8
1600.0000	0.258	-40.2	4.25	-113.8	0.024	42.0	0.465	-53.1	3.53	12.6
1800.0000	0.250	-43.1	4.08	-129.6	0.025	41.4	0.438	-58.6	3.66	12.2
2000.0000	0.242	-46.0	3.82	-145.2	0.026	40.9	0.401	-63.6	3.93	11.6
2200.0000	0.231	-48.7	3.50	-161.3	0.027	40.3	0.352	-68.6	4.35	10.9
2400.0000	0.215	-50.4	3.24	-174.5	0.027	39.8	0.309	-71.9	4.91	10.2
2600.0000	0.195	-51.4	2.97	172.6	0.027	39.2	0.259	-74.4	5.59	9.5
2800.0000	0.175	-52.3	2.69	160.3	0.026	38.7	0.215	-74.1	6.61	8.6
3000.0000	0.153	-51.3	2.41	150.5	0.026	38.2	0.165	-70.8	7.60	7.6

μ PC2746T

V_{CC} = 3.0 V, I_{CC} = 7.5 mA

FREQUENCY MHz	S ₁₁		S ₂₁		S ₁₂		S ₂₂		K	S ₂₁ dB
	MAG	ANG	MAG	ANG	MAG	ANG	MAG	ANG		
100.0000	0.213	164.0	9.11	-6.4	0.001	122.7	0.362	-2.5	45.48	19.2
200.0000	0.204	146.5	9.30	-15.3	0.002	118.8	0.359	-6.0	22.39	19.4
300.0000	0.197	130.0	9.30	-25.0	0.003	114.7	0.365	-9.2	14.88	19.4
400.0000	0.201	117.8	9.23	-34.3	0.004	110.5	0.370	-12.0	11.17	19.3
500.0000	0.209	106.1	9.17	-43.6	0.005	106.6	0.378	-15.6	8.89	19.2
600.0000	0.219	93.9	9.08	-53.0	0.006	102.4	0.382	-19.7	7.41	19.2
700.0000	0.231	87.3	8.91	-62.0	0.008	98.8	0.389	-23.9	5.59	19.0
800.0000	0.242	76.6	8.75	-71.9	0.009	94.6	0.389	-29.0	5.03	18.8
900.0000	0.255	66.3	8.61	-81.5	0.011	90.8	0.393	-34.8	4.13	18.7
1000.0000	0.265	56.2	8.46	-91.9	0.012	87.2	0.385	-40.5	3.86	18.5
1100.0000	0.275	45.6	8.15	-101.4	0.013	83.0	0.381	-47.5	3.68	18.2
1200.0000	0.286	35.5	7.79	-110.5	0.014	79.7	0.368	-52.4	3.59	17.8
1300.0000	0.296	26.5	7.44	-119.6	0.115	76.0	0.335	-58.9	3.53	17.4
1400.0000	0.300	18.6	6.98	-129.1	0.016	74.2	0.335	-64.3	3.57	16.9
1500.0000	0.296	11.5	6.55	-137.8	0.016	72.6	0.314	-70.1	3.88	16.3
1600.0000	0.292	4.7	6.08	-146.4	0.016	71.0	0.290	-75.1	4.27	15.7
1700.0000	0.288	-0.5	5.63	-153.8	0.016	68.9	0.264	-78.7	4.71	15.0
1800.0000	0.285	-4.4	5.21	-161.5	0.017	67.4	0.235	-81.4	4.88	14.3
1900.0000	0.281	-10.1	4.77	-168.8	0.017	65.8	0.206	-83.1	5.42	13.6
2000.0000	0.266	-16.2	4.25	-175.0	0.017	61.3	0.180	-84.8	6.21	12.6

μ PC2747T

V_{CC} = 3.0 V, I_{CC} = 5.0 mA

FREQUENCY MHz	S ₁₁		S ₂₁		S ₁₂		S ₂₂		K	S ₂₁ dB
	MAG	ANG	MAG	ANG	MAG	ANG	MAG	ANG		
100.0000	0.061	-175.8	3.84	-4.0	0.001	120.5	0.249	-1.9	121.68	11.7
200.0000	0.075	-168.9	4.10	-12.5	0.001	118.8	0.255	-4.2	113.38	12.3
300.0000	0.093	-167.4	4.18	-23.0	0.002	117.0	0.261	-5.7	55.26	12.4
400.0000	0.117	-174.1	4.17	-33.0	0.003	115.2	0.266	-7.0	36.64	12.4
500.0000	0.134	175.3	4.15	-42.5	0.004	113.7	0.272	-8.7	27.40	12.4
600.0000	0.142	163.9	4.12	-52.0	0.004	112.2	0.277	-10.6	27.46	12.3
700.0000	0.152	153.7	4.07	-61.1	0.005	110.8	0.281	-13.1	22.12	12.2
800.0000	0.159	142.9	4.02	-70.7	0.006	109.3	0.283	-15.8	18.60	12.1
900.0000	0.154	131.7	3.97	-80.0	0.008	107.8	0.288	-19.3	14.11	12.0
1000.0000	0.148	120.7	3.92	-90.2	0.009	106.3	0.287	-22.6	12.73	11.9
1100.0000	0.143	110.5	3.83	-99.3	0.012	104.8	0.287	-27.6	9.79	11.7
1200.0000	0.139	101.1	3.70	-108.1	0.013	103.4	0.284	-30.2	9.39	11.4
1300.0000	0.135	88.5	3.55	-117.0	0.014	101.9	0.279	-34.7	9.12	11.0
1400.0000	0.131	80.9	3.38	-126.2	0.015	100.4	0.272	-37.3	8.99	10.6
1500.0000	0.126	71.1	3.23	-134.8	0.016	98.0	0.264	-41.3	8.87	10.2
1600.0000	0.121	61.5	3.07	-143.3	0.017	95.6	0.256	-43.7	8.84	9.7
1700.0000	0.120	55.6	2.89	-150.9	0.018	93.2	0.243	-45.8	8.93	9.2
1800.0000	0.118	48.0	2.72	-158.8	0.020	92.6	0.234	-46.2	8.58	8.7
1900.0000	0.113	42.9	2.53	-166.6	0.022	91.6	0.219	-47.0	8.46	8.1
2000.0000	0.105	34.7	2.32	-173.1	0.024	89.2	0.209	-46.4	8.51	7.3

μPC2748T

V_{CC} = 3.0 V, I_{CC} = 6.0 mA

FREQUENCY MHz	S ₁₁		S ₂₁		S ₁₂		S ₂₂		K	S ₂₁ dB
	MAG	ANG	MAG	ANG	MAG	ANG	MAG	ANG		
100.0000	0.102	177.8	5.33	5.9	0.001	82.0	0.294	-0.1	84.81	14.5
200.0000	0.115	-176.8	6.45	1.0	0.001	98.6	0.310	-4.3	69.14	16.2
300.0000	0.138	-177.8	7.11	-10.1	0.002	103.8	0.318	-5.8	31.01	17.0
400.0000	0.166	174.7	7.75	-21.3	0.002	110.7	0.325	-7.6	28.05	17.8
500.0000	0.185	164.2	8.10	-32.3	0.003	117.3	0.338	-10.1	17.59	18.2
600.0000	0.199	150.2	8.44	-44.1	0.004	117.2	0.352	-13.4	12.45	18.5
700.0000	0.211	141.1	8.50	-54.4	0.005	115.5	0.364	-17.0	9.74	18.6
800.0000	0.207	128.8	8.57	-67.4	0.006	114.4	0.376	-22.7	7.98	18.7
900.0000	0.201	111.9	8.64	-79.6	0.008	108.2	0.387	-28.1	5.89	18.7
1000.0000	0.181	93.4	8.63	-94.0	0.009	101.8	0.392	-36.3	5.26	18.7
1100.0000	0.166	81.7	8.38	-104.5	0.011	95.2	0.382	-44.3	4.51	18.5
1200.0000	0.161	71.9	7.71	-115.6	0.011	90.2	0.364	-49.9	4.99	17.7
1300.0000	0.147	57.4	7.30	-126.6	0.011	88.2	0.344	-57.0	5.37	17.3
1400.0000	0.131	47.7	6.67	-137.3	0.012	83.9	0.316	-62.4	5.53	16.5
1500.0000	0.121	37.1	6.21	-146.9	0.011	78.5	0.289	-67.9	6.62	15.9
1600.0000	0.104	26.8	5.70	-156.0	0.011	79.4	0.262	-72.0	7.36	15.1
1700.0000	0.096	21.9	5.19	-163.7	0.012	83.7	0.232	-74.6	7.54	14.3
1800.0000	0.092	16.0	4.74	-171.1	0.013	87.9	0.207	-74.4	7.71	13.5
1900.0000	0.085	12.7	4.21	-179.0	0.014	90.1	0.176	-71.4	8.18	12.5
2000.0000	0.060	7.0	3.99	175.3	0.014	89.4	0.159	-65.0	8.71	12.0

μPC2749T

V_{CC} = 3.0 V, I_{CC} = 6 mA

FREQUENCY MHz	S ₁₁		S ₂₁		S ₁₂		S ₂₂		K	S ₂₁ dB
	MAG	ANG	MAG	ANG	MAG	ANG	MAG	ANG		
100.0000	0.049	1.9	4.67	1.3	0.001	150.9	0.009	-169.1	106.8	13.4
200.0000	0.046	-23.9	4.85	-8.2	0.001	152.4	0.024	107.5	102.8	13.7
300.0000	0.044	-55.1	4.95	-16.8	0.001	153.8	0.041	91.0	100.6	13.9
400.0000	0.043	-89.7	4.97	-23.0	0.001	155.1	0.058	80.0	100.1	13.9
500.0000	0.046	-132.7	4.99	-29.4	0.002	156.4	0.074	72.2	49.7	14.0
600.0000	0.055	-164.0	5.01	-35.3	0.003	155.8	0.089	64.3	32.9	14.0
700.0000	0.071	171.8	5.06	-41.0	0.004	155.9	0.105	56.5	24.3	14.1
800.0000	0.094	153.8	5.19	-47.4	0.005	154.4	0.120	48.4	18.8	14.3
900.0000	0.115	137.5	5.29	-54.0	0.006	152.4	0.138	39.7	15.3	14.5
1000.0000	0.138	127.5	5.51	-59.9	0.008	149.0	0.149	29.3	10.9	14.8
1100.0000	0.165	118.1	5.72	-67.2	0.011	145.4	0.160	20.2	7.6	15.1
1200.0000	0.199	107.8	5.94	-75.2	0.013	140.8	0.170	10.1	6.1	15.5
1300.0000	0.233	98.2	6.14	-84.2	0.016	135.5	0.178	-1.3	4.7	15.8
1400.0000	0.265	89.0	6.33	-93.4	0.019	128.9	0.181	-13.8	3.8	16.0
1500.0000	0.298	80.0	6.46	-103.3	0.021	123.0	0.179	-27.5	3.3	16.2
1600.0000	0.323	70.7	6.48	-113.7	0.024	116.1	0.171	-41.4	2.8	16.2
1700.0000	0.352	61.7	6.38	-124.3	0.025	107.8	0.158	-53.7	2.7	16.1
1800.0000	0.367	53.0	6.25	-133.9	0.027	105.5	0.141	-76.2	2.5	15.9
1900.0000	0.377	45.2	6.10	-144.3	0.028	101.6	0.123	-95.1	2.5	15.7
2000.0000	0.379	37.2	5.86	-153.7	0.031	96.7	0.110	-112.2	2.4	15.4
2100.0000	0.371	30.8	5.47	-163.9	0.032	91.3	0.094	-138.4	2.5	14.8
2200.0000	0.363	26.0	5.18	-172.1	0.032	87.1	0.094	-165.2	2.7	14.3
2300.0000	0.357	22.1	4.81	-179.8	0.033	83.2	0.094	168.2	2.8	13.6
2400.0000	0.350	19.0	4.49	173.0	0.033	80.6	0.104	145.0	3.0	13.0
2500.0000	0.340	16.1	4.17	166.1	0.033	78.6	0.118	126.5	3.2	12.4
2600.0000	0.331	14.4	3.92	160.0	0.033	77.3	0.136	112.6	3.5	11.9
2700.0000	0.321	12.3	3.64	153.7	0.033	76.2	0.155	99.5	3.7	11.2
2800.0000	0.311	11.8	3.44	148.7	0.034	74.8	0.174	91.5	3.8	10.7
2900.0000	0.301	10.8	3.19	142.9	0.035	74.5	0.193	81.5	4.0	10.1
3000.0000	0.290	10.2	3.03	138.1	0.036	73.2	0.210	75.3	4.1	9.6

μPC2711TB

V_{CC} = 5.0 V, I_{CC} = 13.8 mA

FREQUENCY MHz	S ₁₁		S ₂₁		S ₁₂		S ₂₂		K
	MAG	ANG	MAG	ANG	MAG	ANG	MAG	ANG	
100.0000	0.085	-22.4	4.447	-14.9	0.035	-12.7	0.113	-3.1	3.18
200.0000	0.086	-25.0	4.468	-30.1	0.035	-23.0	0.119	1.2	3.21
300.0000	0.098	-29.2	4.491	-44.9	0.034	-32.1	0.136	1.6	3.23
400.0000	0.081	-29.4	4.510	-60.3	0.033	-42.5	0.142	6.5	3.34
500.0000	0.066	-33.9	4.540	-74.9	0.033	-50.1	0.156	10.1	3.32
600.0000	0.041	-54.5	4.572	-90.2	0.033	-59.6	0.161	12.7	3.34
700.0000	0.053	-104.3	4.624	-105.3	0.032	-69.3	0.161	8.8	3.33
800.0000	0.070	-119.7	4.664	-120.7	0.031	-78.4	0.176	6.2	3.36
900.0000	0.098	-121.9	4.729	-136.1	0.032	-86.6	0.192	1.9	3.27
1000.0000	0.101	-112.5	4.781	-152.0	0.031	-94.9	0.228	0.1	3.29
1100.0000	0.090	-108.5	4.843	-167.9	0.031	-103.9	0.256	-0.6	3.15
1200.0000	0.060	-95.6	4.945	175.8	0.029	-111.0	0.290	-1.1	3.24
1300.0000	0.019	-79.2	4.999	159.5	0.029	-120.2	0.308	-0.3	3.16
1400.0000	0.023	54.8	5.062	143.0	0.028	-128.9	0.322	-1.4	3.18
1500.0000	0.062	80.7	5.114	126.4	0.029	-133.1	0.327	-2.2	3.08
1600.0000	0.087	80.4	5.142	109.5	0.029	-140.9	0.333	-4.8	3.07
1700.0000	0.113	78.7	5.160	92.7	0.029	-146.2	0.344	-7.0	3.02
1800.0000	0.126	72.0	5.146	75.4	0.030	-151.4	0.356	-9.7	2.88
1900.0000	0.154	63.5	5.123	58.0	0.032	-159.7	0.371	-11.1	2.70
2000.0000	0.178	59.0	5.113	41.3	0.035	-168.3	0.378	-12.0	2.51
2100.0000	0.212	54.2	5.063	24.0	0.036	-175.7	0.383	-12.8	2.39
2200.0000	0.232	55.2	5.006	6.9	0.038	175.2	0.378	-13.6	2.27
2300.0000	0.246	53.8	4.954	-10.4	0.041	165.2	0.367	-16.1	2.13
2400.0000	0.248	53.6	4.865	-27.7	0.045	155.3	0.359	-18.0	1.99
2500.0000	0.240	49.2	4.783	-45.0	0.048	143.6	0.356	-21.1	1.88
2600.0000	0.238	43.7	4.664	-62.3	0.049	131.2	0.359	-23.6	1.85
2700.0000	0.240	36.2	4.529	-79.6	0.052	119.8	0.366	-26.2	1.76
2800.0000	0.262	31.7	4.384	-96.6	0.054	108.7	0.374	-28.6	1.72
2900.0000	0.285	28.8	4.255	-113.1	0.056	95.5	0.372	-31.1	1.68
3000.0000	0.316	29.7	4.117	-129.6	0.057	83.6	0.361	-35.0	1.69

μPC2712TB

V_{CC} = 5.0 V, I_{CC} = 13.9 mA

FREQUENCY MHz	S ₁₁		S ₂₁		S ₁₂		S ₂₂		K
	MAG	ANG	MAG	ANG	MAG	ANG	MAG	ANG	
100.0000	0.303	-8.1	8.864	-16.7	0.023	-11.4	0.043	2.3	2.32
200.0000	0.291	-10.1	8.827	-33.5	0.023	-19.2	0.055	11.5	2.35
300.0000	0.295	-11.8	8.936	-49.5	0.022	-25.5	0.078	8.5	2.38
400.0000	0.276	-11.3	9.044	-67.6	0.023	-34.6	0.095	13.4	2.33
500.0000	0.265	-11.0	9.051	-82.2	0.023	-42.8	0.112	13.6	2.37
600.0000	0.243	-12.3	9.096	-98.8	0.023	-50.0	0.120	11.1	2.35
700.0000	0.222	-20.3	9.089	-115.2	0.023	-59.8	0.120	1.7	2.37
800.0000	0.219	-25.4	9.080	-131.5	0.023	-66.2	0.136	-6.0	2.38
900.0000	0.230	-33.9	9.096	-147.6	0.023	-73.0	0.155	-14.4	2.39
1000.0000	0.267	-35.5	9.044	-164.2	0.024	-82.9	0.189	-17.5	2.26
1100.0000	0.290	-35.5	9.197	179.5	0.024	-89.5	0.212	-19.9	2.12
1200.0000	0.316	-33.2	9.421	162.4	0.024	-98.4	0.240	-21.4	2.02
1300.0000	0.317	-30.6	9.524	144.9	0.024	-107.0	0.245	-23.2	1.94
1400.0000	0.314	-29.4	9.512	126.6	0.026	-115.7	0.248	-27.1	1.82
1500.0000	0.296	-28.1	9.574	109.1	0.026	-122.3	0.236	-31.8	1.78
1600.0000	0.290	-29.4	9.598	91.1	0.027	-133.2	0.231	-38.0	1.74
1700.0000	0.278	-31.1	9.480	72.9	0.028	-139.4	0.221	-43.8	1.72
1800.0000	0.282	-34.9	9.372	54.3	0.029	-148.1	0.215	-49.8	1.69
1900.0000	0.284	-35.5	9.193	35.6	0.030	-157.6	0.199	-53.0	1.70
2000.0000	0.280	-36.6	9.198	18.4	0.031	-167.4	0.170	-55.3	1.69
2100.0000	0.273	-36.0	9.011	0.1	0.033	-175.1	0.134	-56.2	1.68
2200.0000	0.244	-38.2	8.784	-17.9	0.033	176.5	0.090	-55.2	1.74
2300.0000	0.222	-40.0	8.717	-35.1	0.034	164.8	0.050	-53.7	1.74
2400.0000	0.189	-45.7	8.388	-52.9	0.036	154.8	0.025	1.8	1.75
2500.0000	0.177	-52.9	8.217	-70.1	0.037	143.5	0.039	33.4	1.74
2600.0000	0.164	-57.4	7.890	-87.4	0.039	133.3	0.071	39.3	1.72
2700.0000	0.158	-59.6	7.597	-104.6	0.041	123.8	0.099	34.3	1.70
2800.0000	0.143	-53.9	7.313	-121.4	0.041	114.0	0.131	26.0	1.72
2900.0000	0.128	-44.3	7.078	-138.4	0.043	101.4	0.149	22.8	1.70
3000.0000	0.111	-22.2	6.806	-154.9	0.046	90.2	0.157	19.4	1.70

μPC2745TB

V_{CC} = 3.0 V, I_{CC} = 8.4 mA

FREQUENCY MHz	S ₁₁		S ₂₁		S ₁₂		S ₂₂		K
	MAG	ANG	MAG	ANG	MAG	ANG	MAG	ANG	
100.0000	0.318	-3.9	4.055	-17.2	0.003	62.9	0.593	-6.6	20.94
200.0000	0.325	-5.9	4.030	-35.5	0.006	54.2	0.584	-12.1	11.68
300.0000	0.346	-7.2	3.985	-52.5	0.009	42.0	0.579	-16.5	8.29
400.0000	0.341	-8.9	3.916	-70.7	0.012	29.4	0.562	-20.6	6.26
500.0000	0.339	-10.8	3.842	-87.3	0.013	11.8	0.546	-23.0	6.29
600.0000	0.326	-13.9	3.775	-104.7	0.015	1.6	0.527	-26.2	5.50
700.0000	0.311	-20.8	3.668	-121.5	0.017	-11.9	0.515	-29.9	5.46
800.0000	0.312	-25.8	3.594	-138.1	0.018	-24.2	0.511	-32.4	5.36
900.0000	0.325	-31.9	3.525	-154.2	0.020	-38.4	0.512	-34.8	4.91
1000.0000	0.356	-32.8	3.497	-170.3	0.019	-45.9	0.523	-35.8	4.93
1100.0000	0.382	-32.7	3.503	173.7	0.020	-54.3	0.525	-36.3	4.56
1200.0000	0.416	-31.2	3.542	156.7	0.022	-70.5	0.530	-36.8	4.14
1300.0000	0.416	-30.9	3.569	139.1	0.023	-78.4	0.518	-37.5	3.92
1400.0000	0.415	-30.8	3.520	121.4	0.025	-88.4	0.509	-38.8	3.53
1500.0000	0.393	-30.3	3.501	103.7	0.025	-102.9	0.492	-40.5	3.68
1600.0000	0.386	-31.3	3.429	86.8	0.025	-114.1	0.481	-42.5	3.78
1700.0000	0.373	-30.5	3.355	69.7	0.026	-125.7	0.474	-43.8	3.68
1800.0000	0.369	-31.6	3.303	52.7	0.028	-130.3	0.468	-44.8	3.50
1900.0000	0.366	-29.6	3.229	35.8	0.028	-142.5	0.457	-44.8	3.63
2000.0000	0.353	-30.0	3.179	18.8	0.030	-152.4	0.440	-45.0	3.62
2100.0000	0.344	-28.6	3.081	1.5	0.031	-164.9	0.416	-45.0	3.85
2200.0000	0.313	-29.5	2.999	-15.4	0.031	-177.1	0.389	-45.4	4.23
2300.0000	0.293	-31.6	2.911	-32.5	0.033	171.1	0.365	-46.4	4.23
2400.0000	0.267	-35.1	2.802	-49.4	0.034	160.8	0.346	-47.4	4.40
2500.0000	0.262	-39.9	2.695	-66.0	0.036	148.3	0.331	-48.2	4.45
2600.0000	0.253	-40.3	2.598	-82.3	0.036	134.8	0.321	-48.3	4.54
2700.0000	0.253	-40.9	2.496	-98.6	0.034	121.4	0.311	-47.6	5.08
2800.0000	0.248	-35.5	2.400	-114.6	0.036	106.5	0.299	-46.7	5.01
2900.0000	0.237	-30.2	2.306	-130.2	0.032	92.8	0.279	-46.3	5.88
3000.0000	0.230	-20.6	2.209	-146.4	0.031	83.6	0.254	-46.2	6.49

μPC2746TB

V_{CC} = 3.0 V, I_{CC} = 7.7 mA

FREQUENCY MHz	S ₁₁		S ₂₁		S ₁₂		S ₂₂		K
	MAG	ANG	MAG	ANG	MAG	ANG	MAG	ANG	
100.0000	0.146	165.0	6.443	-19.4	0.001	77.0	0.403	-5.3	108.63
200.0000	0.130	141.7	6.594	-38.7	0.003	51.8	0.406	-8.6	20.56
300.0000	0.117	117.9	6.623	-58.1	0.004	47.7	0.418	-11.0	16.33
400.0000	0.128	100.8	6.522	-77.5	0.005	51.1	0.417	-14.0	12.34
500.0000	0.139	90.8	6.613	-96.9	0.008	33.1	0.424	-16.2	8.14
600.0000	0.145	83.1	6.481	-116.1	0.009	21.7	0.422	-19.4	7.22
700.0000	0.135	77.0	6.424	-135.1	0.010	14.7	0.426	-23.8	6.52
800.0000	0.131	67.4	6.353	-153.6	0.011	-0.4	0.433	-27.7	5.63
900.0000	0.119	49.3	6.234	-172.1	0.014	-10.5	0.442	-32.1	4.80
1000.0000	0.142	30.4	6.137	169.6	0.015	-24.2	0.455	-34.7	4.44
1100.0000	0.170	18.0	5.992	151.1	0.016	-28.7	0.455	-37.5	4.02
1200.0000	0.219	10.6	5.972	133.3	0.019	-48.0	0.453	-39.7	3.49
1300.0000	0.245	7.4	5.867	115.1	0.019	-63.4	0.433	-42.7	3.40
1400.0000	0.268	3.1	5.679	97.0	0.022	-72.2	0.409	-45.5	3.16
1500.0000	0.270	1.5	5.582	79.1	0.021	-86.9	0.375	-48.3	3.38
1600.0000	0.268	-3.9	5.380	61.8	0.022	-99.6	0.349	-49.9	3.36
1700.0000	0.258	-7.8	5.122	44.5	0.024	-110.7	0.318	-50.0	3.42
1800.0000	0.251	-14.3	4.880	27.9	0.024	-122.9	0.294	-49.2	3.67
1900.0000	0.249	-16.7	4.634	11.7	0.025	-135.3	0.268	-45.4	3.73
2000.0000	0.240	-20.5	4.475	-4.4	0.026	-146.0	0.248	-40.5	3.91

μ PC2747TB

V_{CC} = 3.0 V, I_{CC} = 4.9 mA

FREQUENCY MHz	S ₁₁		S ₂₁		S ₁₂		S ₂₂		K
	MAG	ANG	MAG	ANG	MAG	ANG	MAG	ANG	
100.0000	0.951	-178.3	3.732	-3.9	0.001	28.0	0.290	-3.7	98.96
200.0000	0.105	-161.2	3.997	-13.3	0.002	103.2	0.294	-4.3	64.71
300.0000	0.136	-166.8	4.075	-23.4	0.002	76.0	0.292	-3.9	46.80
400.0000	0.165	-172.9	4.105	-32.9	0.004	90.4	0.286	-5.6	29.99
500.0000	0.179	177.8	4.141	-41.2	0.004	89.4	0.298	-6.9	25.94
600.0000	0.185	170.1	4.098	-49.5	0.005	90.7	0.302	-8.4	20.69
700.0000	0.189	162.5	4.124	-57.9	0.006	96.6	0.307	-10.2	17.38
800.0000	0.189	155.1	4.104	-66.3	0.008	101.3	0.309	-12.2	12.59
900.0000	0.182	148.8	4.061	-74.5	0.009	99.2	0.313	-14.4	12.26
1000.0000	0.180	142.6	4.016	-83.0	0.012	99.9	0.316	-16.9	9.45
1100.0000	0.174	137.1	3.977	-91.8	0.013	100.3	0.318	-19.7	8.22
1200.0000	0.160	131.5	3.948	-99.5	0.015	105.5	0.318	-22.6	7.49
1300.0000	0.148	127.4	3.799	-108.4	0.016	96.6	0.318	-24.9	7.42
1400.0000	0.134	124.4	3.736	-115.9	0.019	93.8	0.313	-27.4	6.36
1500.0000	0.124	121.0	3.582	-124.0	0.022	93.8	0.311	-30.1	5.83
1600.0000	0.110	121.0	3.506	-131.7	0.023	88.1	0.312	-31.8	5.55
1700.0000	0.099	122.9	3.317	-138.8	0.025	88.6	0.308	-33.3	5.37
1800.0000	0.089	126.8	3.190	-145.7	0.028	88.3	0.305	-35.1	5.05
1900.0000	0.084	134.8	3.040	-152.8	0.030	80.2	0.305	-37.2	4.98
2000.0000	0.085	141.7	2.901	-159.0	0.032	78.7	0.303	-38.8	4.97
2100.0000	0.087	148.1	2.736	-164.8	0.034	77.6	0.299	-40.9	4.99
2200.0000	0.092	152.1	2.645	-170.8	0.035	73.0	0.304	-41.5	4.97
2300.0000	0.102	156.6	2.507	-176.3	0.037	72.5	0.304	-42.2	4.93
2400.0000	0.114	158.7	2.395	-177.8	0.038	68.5	0.305	-44.7	5.01
2500.0000	0.126	161.4	2.312	-172.9	0.041	66.2	0.317	-45.8	4.76
2600.0000	0.136	160.6	2.218	-168.1	0.042	64.0	0.319	-47.8	4.78
2700.0000	0.154	161.3	2.136	-162.1	0.042	60.4	0.323	-50.8	4.88
2800.0000	0.168	160.4	2.036	-157.8	0.044	54.8	0.331	-54.1	4.88
2900.0000	0.180	157.9	1.952	-151.6	0.044	53.0	0.330	-57.5	5.07
3000.0000	0.196	155.2	1.847	-147.6	0.043	47.2	0.332	-60.9	5.45
3100.0000	0.208	152.5	1.757	-141.6	0.045	44.0	0.331	-65.5	5.49

μ PC2748TB

V_{CC} = 3.0 V, I_{CC} = 6.3 mA

FREQUENCY MHz	S ₁₁		S ₂₁		S ₁₂		S ₂₂		K
	MAG	ANG	MAG	ANG	MAG	ANG	MAG	ANG	
100.0000	0.120	-177.2	4.730	5.3	0.000	-30.4	0.280	-2.2	352.73
200.0000	0.136	-167.3	5.430	-0.2	0.001	19.3	0.285	-2.4	72.83
300.0000	0.166	-174.2	5.930	-9.2	0.001	97.8	0.286	-0.9	52.47
400.0000	0.194	179.6	6.314	-18.8	0.003	125.4	0.291	-2.7	24.77
500.0000	0.210	169.6	6.701	-28.2	0.004	108.7	0.306	-3.7	16.82
600.0000	0.213	160.0	6.876	-38.8	0.005	107.4	0.319	-5.4	12.40
700.0000	0.213	150.2	7.203	-49.3	0.006	98.7	0.337	-8.4	10.09
800.0000	0.211	140.8	7.310	-60.6	0.009	114.1	0.349	-12.3	6.68
900.0000	0.203	131.1	7.354	-71.5	0.010	107.6	0.360	-17.4	5.68
1000.0000	0.193	121.1	7.371	-81.9	0.012	98.3	0.371	-22.7	4.71
1100.0000	0.180	110.8	7.346	-92.8	0.014	99.1	0.366	-28.9	3.98
1200.0000	0.159	100.6	7.334	-102.4	0.015	97.5	0.359	-35.3	4.01
1300.0000	0.136	90.6	7.001	-112.6	0.016	91.4	0.342	-40.7	3.95
1400.0000	0.115	79.2	6.834	-121.3	0.018	84.1	0.320	-46.0	3.71
1500.0000	0.096	70.4	6.437	-130.1	0.019	84.8	0.296	-50.5	3.77
1600.0000	0.072	60.9	6.181	-138.2	0.020	82.4	0.271	-53.0	3.81
1700.0000	0.049	47.5	5.710	-145.4	0.020	78.9	0.247	-55.1	4.13
1800.0000	0.024	36.5	5.372	-152.5	0.021	73.5	0.228	-55.7	4.22
1900.0000	0.007	-6.0	5.014	-158.6	0.021	74.1	0.208	-55.7	4.57
2000.0000	0.014	-126.0	4.724	-164.1	0.024	74.9	0.198	-52.8	4.37
2100.0000	0.034	-141.3	4.405	-169.7	0.024	71.5	0.188	-52.1	4.70
2200.0000	0.047	-147.7	4.175	-174.7	0.026	73.6	0.190	-47.8	4.44
2300.0000	0.063	-156.9	3.933	-179.5	0.026	71.2	0.185	-45.3	4.81
2400.0000	0.079	-161.1	3.738	-175.3	0.028	69.1	0.192	-44.7	4.58
2500.0000	0.094	-165.5	3.579	-171.2	0.030	63.8	0.202	-43.2	4.48
2600.0000	0.108	-169.0	3.411	-166.5	0.030	64.7	0.214	-43.6	4.59
2700.0000	0.123	-174.7	3.283	-161.4	0.032	64.6	0.222	-45.7	4.54
2800.0000	0.139	-178.9	3.107	-157.3	0.031	58.9	0.238	-47.6	4.83
2900.0000	0.151	-175.9	2.989	-151.4	0.032	53.2	0.240	-52.4	4.84
3000.0000	0.164	-170.5	2.814	-147.3	0.033	51.6	0.251	-55.8	4.99
3100.0000	0.178	-166.0	2.680	-141.5	0.034	47.3	0.254	-61.4	5.07

μPC2749TB

V_{CC} = 3.0 V, I_{CC} = 6.8 mA

FREQUENCY MHz	S ₁₁		S ₂₁		S ₁₂		S ₂₂		K
	MAG	ANG	MAG	ANG	MAG	ANG	MAG	ANG	
100.0000	0.021	13.0	4.096	-1.9	0.002	-1.1	0.024	165.8	66.82
200.0000	0.038	-30.5	4.216	-7.8	0.001	75.4	0.033	113.6	129.26
300.0000	0.034	-71.8	4.282	-15.5	0.001	141.5	0.064	96.1	90.16
400.0000	0.052	-120.5	4.403	-21.0	0.002	129.9	0.080	87.9	45.30
500.0000	0.062	-149.9	4.390	-26.6	0.002	134.1	0.103	76.9	57.58
600.0000	0.079	-169.7	4.399	-31.6	0.003	128.3	0.127	68.6	34.08
700.0000	0.097	173.6	4.566	-36.7	0.005	132.9	0.151	60.6	22.08
800.0000	0.116	160.5	4.667	-41.3	0.007	131.5	0.174	53.7	14.70
900.0000	0.134	149.3	4.843	-46.8	0.008	129.3	0.197	44.9	12.29
1000.0000	0.156	138.8	5.016	-52.6	0.009	124.6	0.220	36.1	10.00
1100.0000	0.178	128.5	5.305	-60.3	0.014	131.4	0.240	28.0	6.15
1200.0000	0.195	118.7	5.660	-67.1	0.016	122.5	0.262	17.3	5.13
1300.0000	0.214	108.7	5.835	-76.2	0.020	118.6	0.279	8.6	3.80
1400.0000	0.229	99.5	6.148	-84.5	0.022	114.4	0.287	-2.0	3.23
1500.0000	0.249	89.4	6.364	-93.8	0.025	107.7	0.294	-13.5	2.72
1600.0000	0.259	79.9	6.611	-103.6	0.028	104.3	0.294	-23.6	2.35
1700.0000	0.264	69.8	6.577	-113.5	0.032	96.8	0.283	-33.8	2.09
1800.0000	0.259	60.3	6.549	-123.4	0.034	91.8	0.272	-44.1	1.99
1900.0000	0.248	50.9	6.407	-132.9	0.036	83.3	0.256	-53.8	1.97
2000.0000	0.238	43.6	6.321	-140.8	0.037	78.5	0.234	-61.4	1.99
2100.0000	0.218	35.9	6.046	-148.8	0.038	75.1	0.213	-69.5	2.04
2200.0000	0.204	30.1	5.862	-156.5	0.039	70.4	0.193	-73.8	2.08
2300.0000	0.183	25.3	5.696	-163.2	0.040	68.3	0.174	-79.5	2.15
2400.0000	0.156	21.2	5.430	-170.5	0.041	60.7	0.164	-84.1	2.25
2500.0000	0.140	18.8	5.282	-176.3	0.042	61.6	0.152	-82.1	2.25
2600.0000	0.119	18.7	5.013	177.2	0.040	58.1	0.142	-84.5	2.53
2700.0000	0.095	21.2	4.849	170.9	0.042	55.1	0.146	-85.5	2.46
2800.0000	0.078	30.0	4.596	164.9	0.042	51.9	0.149	-83.9	2.62
2900.0000	0.066	44.5	4.446	158.1	0.042	44.7	0.154	-91.8	2.70
3000.0000	0.070	66.0	4.163	152.3	0.044	41.9	0.171	-92.8	2.73
3100.0000	0.082	78.1	3.966	145.3	0.042	37.1	0.181	-99.6	2.97

μPC3210TB

V_{CC} = 5.0 V, I_{CC} = 16.0 mA

FREQUENCY MHz	S ₁₁		S ₂₁		S ₁₂		S ₂₂		K
	MAG	ANG	MAG	ANG	MAG	ANG	MAG	ANG	
100.0000	0.358	171.9	8.688	-4.4	0.019	-1.4	0.233	-6.8	2.63
200.0000	0.335	166.6	8.807	-10.6	0.019	3.3	0.237	-12.0	2.71
300.0000	0.321	160.7	8.821	-17.1	0.019	6.3	0.233	-15.1	2.68
400.0000	0.306	158.3	8.841	-23.3	0.019	9.9	0.233	-20.6	2.68
500.0000	0.294	154.4	8.908	-29.2	0.019	13.6	0.241	-25.6	2.67
600.0000	0.283	151.8	8.990	-35.1	0.019	15.8	0.246	-30.8	2.74
700.0000	0.273	148.6	9.160	-41.0	0.019	19.5	0.250	-35.8	2.67
800.0000	0.267	146.0	9.342	-47.3	0.018	24.3	0.256	-41.2	2.65
900.0000	0.260	144.2	9.541	-53.9	0.018	29.8	0.263	-47.9	2.69
1000.0000	0.252	141.5	9.741	-60.8	0.019	28.9	0.274	-53.1	2.46
1100.0000	0.246	138.4	10.071	-68.6	0.019	29.4	0.283	-59.0	2.37
1200.0000	0.239	135.9	10.393	-76.3	0.018	36.7	0.291	-65.7	2.38
1300.0000	0.229	133.3	10.513	-85.4	0.019	38.1	0.299	-71.9	2.25
1400.0000	0.224	131.1	10.763	-94.5	0.019	45.6	0.303	-79.7	2.20
1500.0000	0.215	127.4	10.708	-104.0	0.021	48.2	0.311	-87.6	2.05
1600.0000	0.203	125.8	10.720	-114.2	0.021	48.9	0.316	-94.9	2.07
1700.0000	0.191	123.1	10.388	-124.1	0.023	55.7	0.308	-103.4	1.98
1800.0000	0.179	122.1	9.993	-133.7	0.023	59.5	0.303	-111.5	2.02
1900.0000	0.163	121.0	9.507	-142.8	0.025	61.9	0.291	-119.5	2.01
2000.0000	0.155	123.4	8.983	-151.2	0.024	65.9	0.275	-128.4	2.17
2100.0000	0.140	126.1	8.384	-158.9	0.027	69.0	0.255	-135.0	2.14
2200.0000	0.133	129.1	7.905	-166.0	0.029	70.7	0.230	-140.5	2.12
2300.0000	0.130	135.3	7.412	-172.3	0.032	71.8	0.207	-145.9	2.10
2400.0000	0.133	139.0	6.976	-178.6	0.034	74.3	0.182	-150.3	2.12
2500.0000	0.137	144.0	6.582	-176.1	0.038	73.2	0.157	-151.8	2.06
2600.0000	0.149	148.5	6.202	170.4	0.039	71.4	0.136	-152.1	2.13
2700.0000	0.157	150.2	5.942	164.9	0.043	73.7	0.116	-147.1	2.03
2800.0000	0.170	152.2	5.567	159.7	0.045	72.2	0.102	-137.8	2.04
2900.0000	0.181	150.3	5.360	153.9	0.047	72.5	0.099	-132.3	2.03
3000.0000	0.203	149.0	5.013	149.0	0.048	69.6	0.104	-122.3	2.10
3100.0000	0.209	147.9	4.810	142.9	0.051	71.0	0.117	-114.4	2.08

[MEMO]

Facsimile Message

Although NEC has taken all possible steps to ensure that the documentation supplied to our customers is complete, bug free and up-to-date, we readily accept that errors may occur. Despite all the care and precautions we've taken, you may encounter problems in the documentation. Please complete this form whenever you'd like to report errors or suggest improvements to us.

From:

Name

Company

Tel.

FAX

Address

Thank you for your kind support.

North America

NEC Electronics Inc.
Corporate Communications Dept.
Fax: 1-800-729-9288
1-408-588-6130

Hong Kong, Philippines, Oceania

NEC Electronics Hong Kong Ltd.
Fax: +852-2886-9022/9044

Asian Nations except Philippines

NEC Electronics Singapore Pte. Ltd.
Fax: +65-250-3583

Europe

NEC Electronics (Europe) GmbH
Technical Documentation Dept.
Fax: +49-211-6503-274

Korea

NEC Electronics Hong Kong Ltd.
Seoul Branch
Fax: 02-528-4411

Japan

NEC Semiconductor Technical Hotline
Fax: 044-548-7900

South America

NEC do Brasil S.A.
Fax: +55-11-6465-6829

Taiwan

NEC Electronics Taiwan Ltd.
Fax: 02-2719-5951

I would like to report the following error/make the following suggestion:

Document title: _____

Document number: _____ Page number: _____

If possible, please fax the referenced page or drawing.

Document Rating	Excellent	Good	Acceptable	Poor
Clarity	<input type="checkbox"/>	<input type="checkbox"/>	<input type="checkbox"/>	<input type="checkbox"/>
Technical Accuracy	<input type="checkbox"/>	<input type="checkbox"/>	<input type="checkbox"/>	<input type="checkbox"/>
Organization	<input type="checkbox"/>	<input type="checkbox"/>	<input type="checkbox"/>	<input type="checkbox"/>