

# DATA SHEET

# NEC

## SILICON POWER MOS FET NE5500434

### N-CHANNEL SILICON POWER MOS FET POWER AMPLIFIER FOR GSM CLASS 4 HANDSETS

#### DESCRIPTION

The NE5500434 is an N-channel silicon power MOS FET specially designed as the transmission power amplifier for GSM class 4 handsets. Dies are manufactured using our NEWMOS technology (our 0.6  $\mu$ m WSi gate lateral MOS FET), housed in a surface mount 3-pin power minimold (34 PKG) (SOT-89 type) package. The device can deliver 35 dBm output power with 63% power added efficiency at 900 MHz under the 4.8 V supply voltage.

The NE5500434 also can deliver 31.5 dBm output power with 60% power added efficiency at 3.6 V.

#### FEATURES

- High output power :  $P_{out} = 35$  dBm TYP. ( $V_{DS} = 4.8$  V,  $f = 900$  MHz,  $P_{in} = 25$  dBm)  
:  $P_{out} = 31.5$  dBm TYP. ( $V_{DS} = 3.6$  V,  $f = 900$  MHz,  $P_{in} = 20$  dBm)
- High power added efficiency :  $\eta_{add} = 60\%$  TYP. ( $V_{DS} = 4.8$  V,  $f = 900$  MHz)
- High linear gain :  $G_L = 14.0$  dB TYP. ( $V_{DS} = 4.8$  V,  $f = 900$  MHz)
- Surface mount package : 3-pin power minimold (34 PKG) (SOT-89 type)
- Single supply :  $V_{DS} = 4.8$  V for GSM class 4 handsets

#### APPLICATIONS

- Digital cellular phones : GSM class 4 handsets
- <R> • Handheld transceiver : FRS (Family Radio Service), GMRS (General Mobile Radio Service)
- Others : General purpose amplifiers for 800 to 1 000 MHz TDMA applications

#### <R> ORDERING INFORMATION

Part Number	Order Number	Package	Marking	Supplying Form
NE5500434	NE5500434-AZ	3-pin power minimold (SOT-89, Our code: 34) (Pb-Free : External solder plating)	V4	<ul style="list-style-type: none"> <li>• Magazine case</li> <li>• Qty 25 pcs/case</li> </ul>
NE5500434-T1	NE5500434-T1-AZ	3-pin power minimold (SOT-89, Our code: 34) (Pb-Free : External solder plating)		<ul style="list-style-type: none"> <li>• 12 mm wide embossed taping</li> <li>• Source pin face the perforation side of the tape</li> <li>• Qty 1 kpcs/reel</li> </ul>

**Remarks 1.** To order evaluation samples, contact your nearby sales office.

Part number for sample order: NE5500434

**2.** This product is containing Pb-material inside.

**Caution** Observe precautions when handling because these devices are sensitive to electrostatic discharge.

The information in this document is subject to change without notice. Before using this document, please confirm that this is the latest version.  
Not all products and/or types are available in every country. Please check with an NEC Electronics sales representative for availability and additional information.

**ABSOLUTE MAXIMUM RATINGS (T<sub>A</sub> = +25°C)**

Operation in excess of any one of these parameters may result in permanent damage.

Parameter	Symbol	Ratings	Unit
Drain to Source Voltage	V <sub>DS</sub>	20	V
Gate to Source Voltage	V <sub>GS</sub>	6.0	V
Drain Current	I <sub>D</sub>	2.0	A
Total Power Dissipation	P <sub>tot</sub>	10	W
Channel Temperature	T <sub>ch</sub>	125	°C
Storage Temperature	T <sub>stg</sub>	-65 to +125	°C

**RECOMMENDED OPERATING CONDITIONS**

Parameter	Symbol	Test Conditions	MIN.	TYP.	MAX.	Unit
Drain to Source Voltage	V <sub>DS</sub>		3.0	4.8	6.0	V
Gate to Source Voltage	V <sub>GS</sub>		0	2.0	3.5	V
Drain Current	I <sub>D</sub>	Duty Cycle ≤ 50%, T <sub>on</sub> ≤ 1 s	-	1.0	1.5	A
Input Power	P <sub>in</sub>	f = 900 MHz, V <sub>DS</sub> = 4.8 V	-	-	27	dBm

**ELECTRICAL CHARACTERISTICS**

(T<sub>A</sub> = +25°C, unless otherwise specified, using our standard test fixture.)

Parameter	Symbol	Test Conditions	MIN.	TYP.	MAX.	Unit
Gate to Source Leakage Current	I <sub>ISO</sub>	V <sub>GS</sub> = 6.0 V	-	-	100	nA
Drain to Source Leakage Current (Zero Gate Voltage Drain Current)	I <sub>DSS</sub>	V <sub>DS</sub> = 8.5 V	-	-	100	nA
Gate Threshold Voltage	V <sub>th</sub>	V <sub>DS</sub> = 4.8 V, I <sub>DS</sub> = 1 mA	1.0	1.35	2.0	V
Thermal Resistance	R <sub>th</sub>	Channel to Case	-	10	-	°C/W
Transconductance	g <sub>m</sub>	V <sub>DS</sub> = 4.8 V, I <sub>DS</sub> = 600 mA	-	1.43	-	S
Drain to Source Breakdown Voltage	BV <sub>DSS</sub>	I <sub>DSS</sub> = 10 μA	20	24	-	V
Output Power	P <sub>out</sub>	f = 900 MHz, V <sub>DS</sub> = 4.8 V,	34.0	35.0	-	dBm
Drain Current	I <sub>D</sub>	P <sub>in</sub> = 25 dBm, I <sub>Dset</sub> = 600 mA (RF OFF)	-	990	-	mA
Power Added Efficiency	η <sub>add</sub>		53	60	-	%
Linear Gain <sup>Note</sup>	G <sub>L</sub>		12.0	14.0	-	dB

**Note** P<sub>in</sub> = 10 dBm

DC performance is 100% testing. RF performance is testing several samples per wafer.

Wafer rejection criteria for standard devices is 1 reject for several samples.

<R> TYPICAL CHARACTERISTICS (T<sub>A</sub> = +25°C)

DRAIN CURRENT vs. DRAIN TO SOURCE VOLTAGE

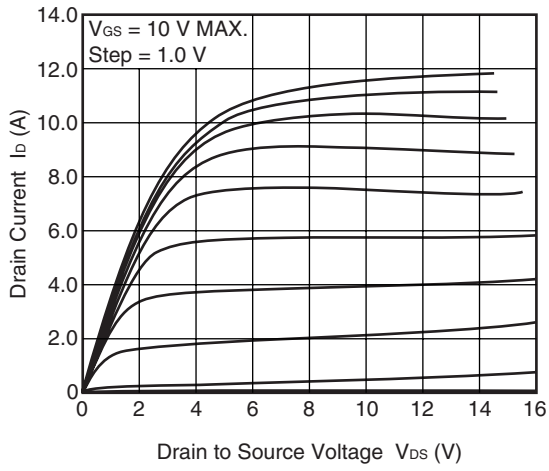

SET DRAIN CURRENT vs. GATE TO SOURCE VOLTAGE

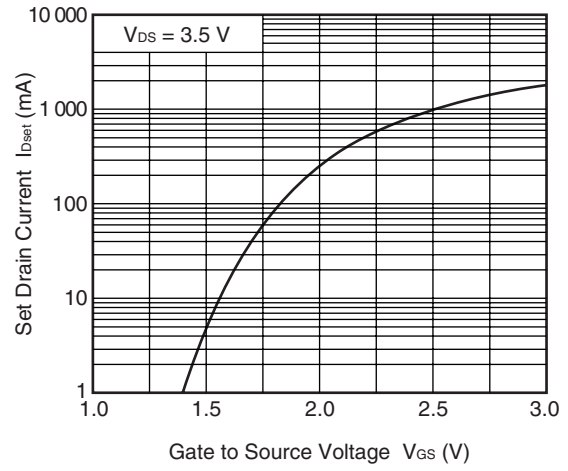

OUTPUT POWER, EFFICIENCY vs. INPUT POWER

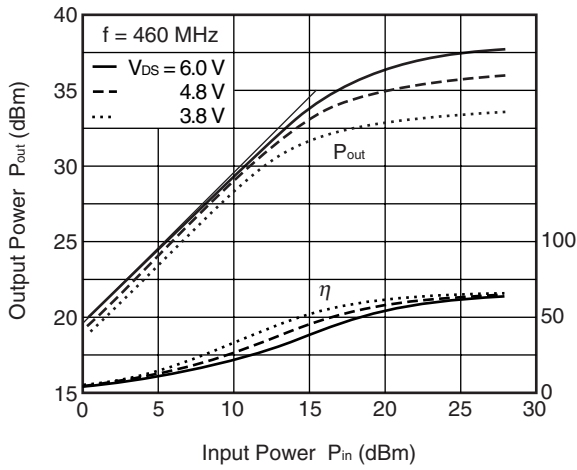

DRAIN CURRENT vs. INPUT POWER

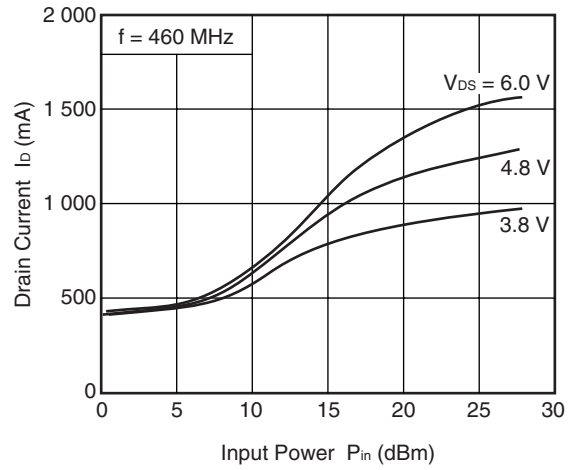

**Remark** The graphs indicate nominal characteristics.

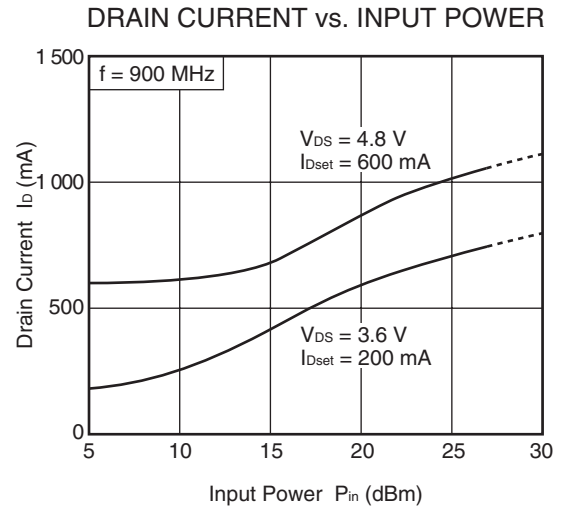
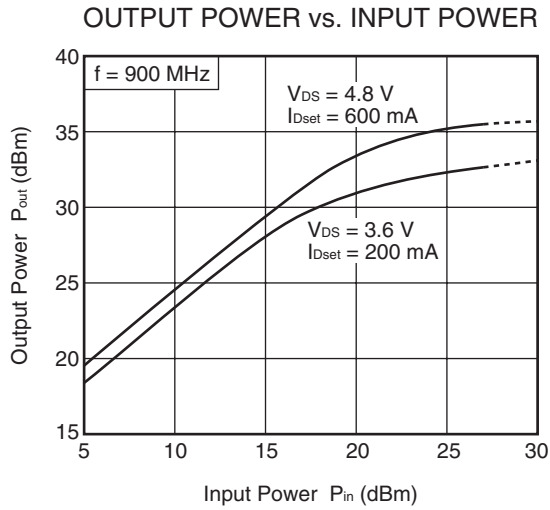

### POWER ADDED EFFICIENCY vs. INPUT POWER

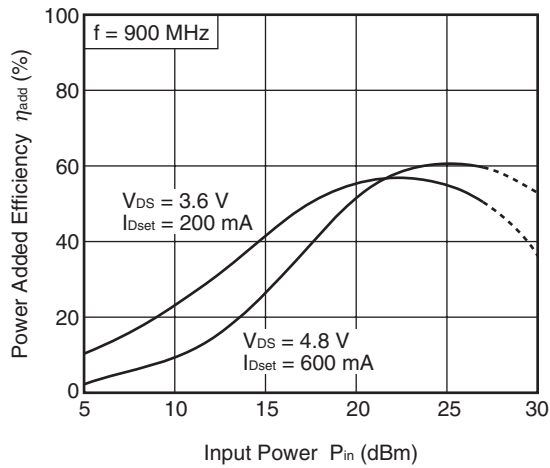

**Remark** The graphs indicate nominal characteristics.

PACKAGE DIMENSIONS

3-PIN POWER MINIMOLD (34 PKG) (UNIT: mm)

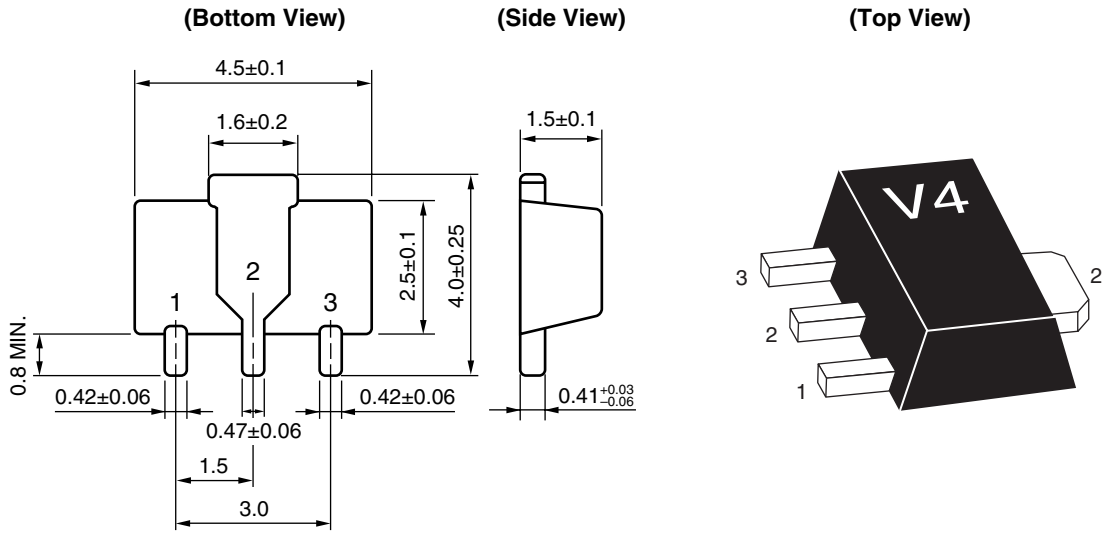

PIN CONNECTIONS

- 1. Drain
- 2. Source
- 3. Gate

<R> **RECOMMENDED SOLDERING CONDITIONS**

This product should be soldered and mounted under the following recommended conditions. For soldering methods and conditions other than those recommended below, contact your nearby sales office.

Soldering Method	Soldering Conditions	Condition Symbol
Infrared Reflow	Peak temperature (package surface temperature) : 260°C or below Time at peak temperature : 10 seconds or less Time at temperature of 220°C or higher : 60 seconds or less Preheating time at 120 to 180°C : 120±30 seconds Maximum number of reflow processes : 3 times Maximum chlorine content of rosin flux (% mass) : 0.2%(Wt.) or below	IR260
Wave Soldering	Peak temperature (molten solder temperature) : 260°C or below Time at peak temperature : 10 seconds or less Preheating temperature (package surface temperature) : 120°C or below Maximum number of flow processes : 1 time Maximum chlorine content of rosin flux (% mass) : 0.2%(Wt.) or below	WS260
Partial Heating	Peak temperature (terminal temperature) : 350°C or below Soldering time (per side of device) : 3 seconds or less Maximum chlorine content of rosin flux (% mass) : 0.2%(Wt.) or below	HS350

**Caution Do not use different soldering methods together (except for partial heating).**

• **The information in this document is current as of August, 2007. The information is subject to change without notice. For actual design-in, refer to the latest publications of NEC Electronics data sheets or data books, etc., for the most up-to-date specifications of NEC Electronics products. Not all products and/or types are available in every country. Please check with an NEC Electronics sales representative for availability and additional information.**

- No part of this document may be copied or reproduced in any form or by any means without the prior written consent of NEC Electronics. NEC Electronics assumes no responsibility for any errors that may appear in this document.
- NEC Electronics does not assume any liability for infringement of patents, copyrights or other intellectual property rights of third parties by or arising from the use of NEC Electronics products listed in this document or any other liability arising from the use of such products. No license, express, implied or otherwise, is granted under any patents, copyrights or other intellectual property rights of NEC Electronics or others.
- Descriptions of circuits, software and other related information in this document are provided for illustrative purposes in semiconductor product operation and application examples. The incorporation of these circuits, software and information in the design of a customer's equipment shall be done under the full responsibility of the customer. NEC Electronics assumes no responsibility for any losses incurred by customers or third parties arising from the use of these circuits, software and information.
- While NEC Electronics endeavors to enhance the quality, reliability and safety of NEC Electronics products, customers agree and acknowledge that the possibility of defects thereof cannot be eliminated entirely. To minimize risks of damage to property or injury (including death) to persons arising from defects in NEC Electronics products, customers must incorporate sufficient safety measures in their design, such as redundancy, fire-containment and anti-failure features.
- NEC Electronics products are classified into the following three quality grades: "Standard", "Special" and "Specific".

The "Specific" quality grade applies only to NEC Electronics products developed based on a customer-designated "quality assurance program" for a specific application. The recommended applications of an NEC Electronics product depend on its quality grade, as indicated below. Customers must check the quality grade of each NEC Electronics product before using it in a particular application.

"Standard": Computers, office equipment, communications equipment, test and measurement equipment, audio and visual equipment, home electronic appliances, machine tools, personal electronic equipment and industrial robots.

"Special": Transportation equipment (automobiles, trains, ships, etc.), traffic control systems, anti-disaster systems, anti-crime systems, safety equipment and medical equipment (not specifically designed for life support).

"Specific": Aircraft, aerospace equipment, submersible repeaters, nuclear reactor control systems, life support systems and medical equipment for life support, etc.

The quality grade of NEC Electronics products is "Standard" unless otherwise expressly specified in NEC Electronics data sheets or data books, etc. If customers wish to use NEC Electronics products in applications not intended by NEC Electronics, they must contact an NEC Electronics sales representative in advance to determine NEC Electronics' willingness to support a given application.

(Note)

- (1) "NEC Electronics" as used in this statement means NEC Electronics Corporation and also includes its majority-owned subsidiaries.
- (2) "NEC Electronics products" means any product developed or manufactured by or for NEC Electronics (as defined above).