

2-PIN POWER MINI MOLD
SC-62 (Power Mini Mold)
SC-84 (MP-2)

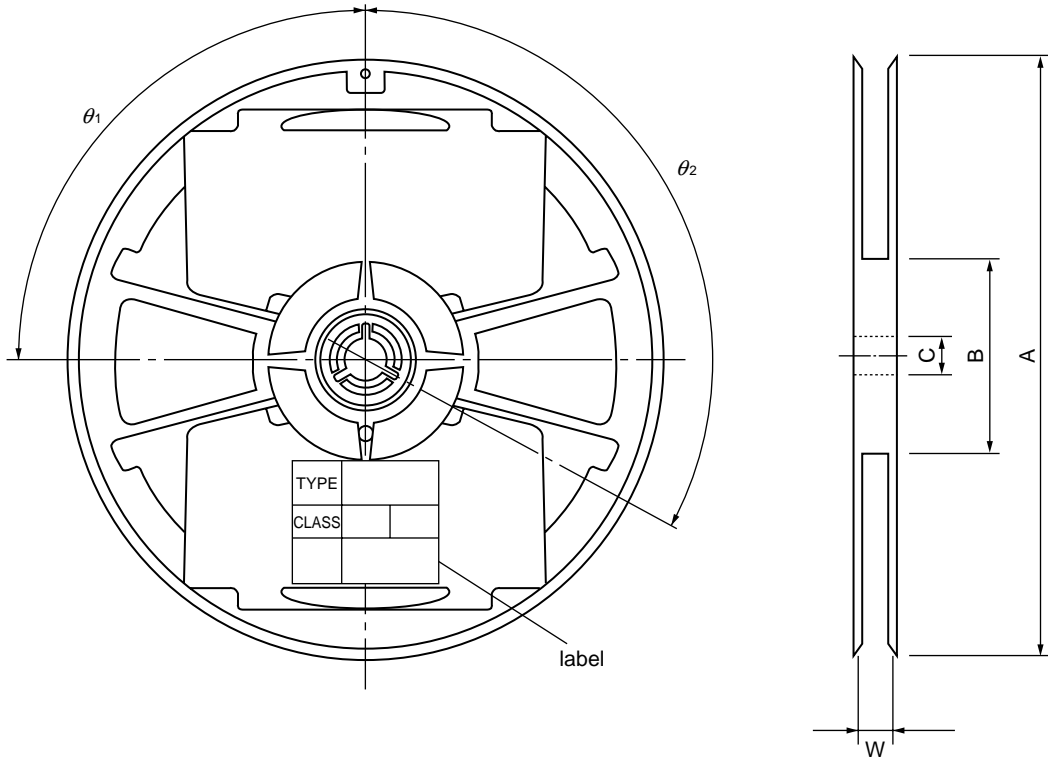

UNIT:mm

ITEM		SYMBOL	SIZE	REMARKS
Flange	Diameter	A	$\phi 178\pm 2$	
	Space Between Flanges	W	13 ± 0.5	
Hub	Outer Diameter	B	$\phi 60\pm 1$	
	Slit Location	θ_1	90°	
	Spindle Hole Diameter	C	$\phi 13\pm 0.5$	
	Key Slit Location	θ_2	120°	
Marking				Type no., quantity and lot code are marked or labeled.