

SC-62 (Power Mini Mold)

SC-84 (MP-2)

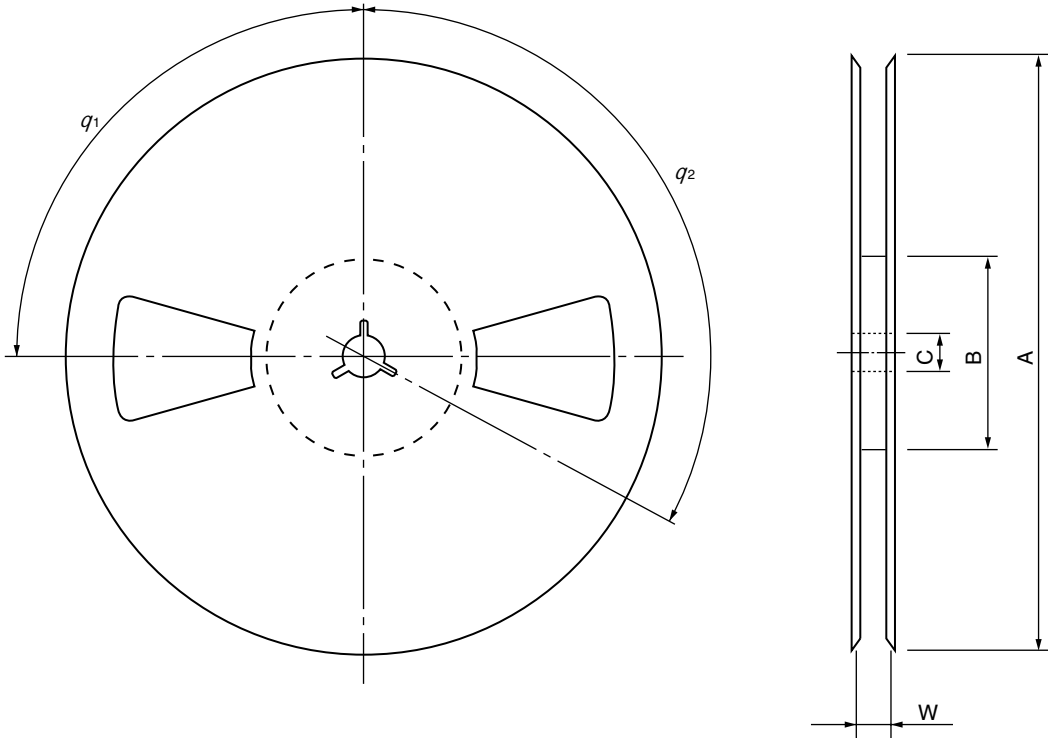

UNIT : mm

ITEM		SYMBOL	SIZE	REMARKS
Flange	Diameter	A	$f178\pm 2$	
	Space Between Flanges	W	13 ± 0.5	
Hub	Outer Diameter	B	$f60\pm 1$	
	Slit Location	q_1	90°	
	Spindle Hole Diameter	C	$f13\pm 0.5$	
	Key Slit Location	q_2	120°	
Marking				Type no., quantity and lot code are marked or labeled.