

PRODUCT BRIEF

μPD720171

WIRELESS USB HOST CONTROLLER

The μPD720171 is the Wireless Universal Serial Bus (Wireless USB) host controller, certified by USB Implementers Forum (USB-IF). Also, the μPD720171 complies with WiMedia® MAC specification, and Intel's Wireless Host Controller Interface Specification.

The μPD720171 has PCI Express® bus interface, and it is applicable for PCI Express solution for host PC system. The μPD720171 works up to 480 Mbps for data transfer when connecting to Wireless USB compliant peripherals.

The μPD720171 has MAC-PHY interface which complies with WiMedia MAC-PHY interface specification, builds up with WiMedia PHY to Wireless USB host system.

FEATURES

- Compliant with Wireless Universal Serial Bus specification Revision 1.0, that released by USB Implementers Forum, Inc
 - Supports eight speed of data rate as follows; 53.3 / 80.0 / 106.7 / 160 / 200 / 320 / 400 / , 480 Mbps
 - Supports three USB compliant data transfer type as follows; Control / Bulk / Interrupt transfer. (Except for Isochronous transfer type) and Wireless USB compliant Device Notification
 - Supports up to 32 connections to physical Wireless USB compliant devices
 - Supports AES-128 CCM
- Compliant with Intel's Wireless Host Controller Interface (WHCI) Specification revision 0.96
- Compliant with WiMedia Distributed Media Access Controller (MAC) for Wireless Networks release 1.2
- Compliant with WiMedia MAC-PHY interface specification revision 1.2
- Compliant with PCI Express Base Specification 1.1
- Supports ExpressCard™ Standard Release1.0
- Supports PCI Express Mini Card Electromechanical Specification Revision 1.2
- Supports PCI Express Card Electromechanical Specification Revision 1.1
- Supports PCI Bus Power Management Interface Specification revision 1.1
- Self Beaconsing Device
- Supports distributed reservation protocol
- Operational registers are direct-mapped to PCI memory space
- Supports indicator for host controller status with LED
- Supports Serial Peripheral Interface (SPI) type ROM
- System clock is generated by 30 MHz crystal.
- 3.3 V and 1.5 V power supply

BLOCK DIAGRAM

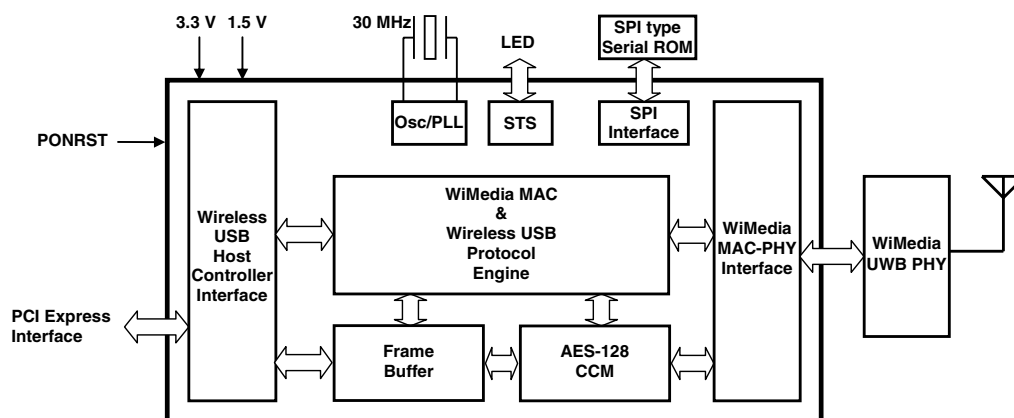

PACKAGE

- 129-pin plastic FBGA (9x9)

APPLICATION

- PC peripherals
 - PCI Express MiniCard
 - ExpressCard
 - PCI Express Card

All logo, trademarks or registered trademarks mentioned in this document are the intellectual property of their respective owners.

These commodities, technology or software, must be exported in accordance with the export administration regulations of the exporting country. Diversion contrary to the law of that country is prohibited.

- **The information in this document is current as of July, 2008. The information is subject to change without notice. For actual design-in, refer to the latest publications of NEC Electronics data sheets or data books, etc., for the most up-to-date specifications of NEC Electronics products. Not all products and/or types are available in every country. Please check with an NEC Electronics sales representative for availability and additional information.**
- No part of this document may be copied or reproduced in any form or by any means without the prior written consent of NEC Electronics. NEC Electronics assumes no responsibility for any errors that may appear in this document.
- NEC Electronics does not assume any liability for infringement of patents, copyrights or other intellectual property rights of third parties by or arising from the use of NEC Electronics products listed in this document or any other liability arising from the use of such products. No license, express, implied or otherwise, is granted under any patents, copyrights or other intellectual property rights of NEC Electronics or others.
- Descriptions of circuits, software and other related information in this document are provided for illustrative purposes in semiconductor product operation and application examples. The incorporation of these circuits, software and information in the design of a customer's equipment shall be done under the full responsibility of the customer. NEC Electronics assumes no responsibility for any losses incurred by customers or third parties arising from the use of these circuits, software and information.
- While NEC Electronics endeavors to enhance the quality, reliability and safety of NEC Electronics products, customers agree and acknowledge that the possibility of defects thereof cannot be eliminated entirely. To minimize risks of damage to property or injury (including death) to persons arising from defects in NEC Electronics products, customers must incorporate sufficient safety measures in their design, such as redundancy, fire-containment and anti-failure features.
- NEC Electronics products are classified into the following three quality grades: "Standard", "Special" and "Specific".
 The "Specific" quality grade applies only to NEC Electronics products developed based on a customer-designated "quality assurance program" for a specific application. The recommended applications of an NEC Electronics product depend on its quality grade, as indicated below. Customers must check the quality grade of each NEC Electronics product before using it in a particular application.
 - "Standard": Computers, office equipment, communications equipment, test and measurement equipment, audio and visual equipment, home electronic appliances, machine tools, personal electronic equipment and industrial robots.
 - "Special": Transportation equipment (automobiles, trains, ships, etc.), traffic control systems, anti-disaster systems, anti-crime systems, safety equipment and medical equipment (not specifically designed for life support).
 - "Specific": Aircraft, aerospace equipment, submersible repeaters, nuclear reactor control systems, life support systems and medical equipment for life support, etc.

The quality grade of NEC Electronics products is "Standard" unless otherwise expressly specified in NEC Electronics data sheets or data books, etc. If customers wish to use NEC Electronics products in applications not intended by NEC Electronics, they must contact an NEC Electronics sales representative in advance to determine NEC Electronics' willingness to support a given application.

(Note)

- (1) "NEC Electronics" as used in this statement means NEC Electronics Corporation and also includes its majority-owned subsidiaries.
- (2) "NEC Electronics products" means any product developed or manufactured by or for NEC Electronics (as defined above).